

1. Installation and Quick Configuration Manual	3
1.1 Introduction	4
1.1.1 Product description	4
1.1.2 Document overview	4
1.1.3 Related documents	5
1.1.4 Additional options	5
1.1.5 Certificates	9
1.2 Comparison chart: Master modules	9
1.3 Comparison chart: Extension unit and CAN modules/sensors	11
1.4 Comparison chart: Metered power monitoring units	12
1.5 Physical description	14
1.5.1 Master module panels	14
1.5.2 Modules and sensors panels	17
1.6 Inventory	20
1.6.1 VT8101 package content	20
1.6.2 VT8101T package content	21
1.6.3 VT8110 package content	21
1.6.4 VT1808, VT1908 package content	22
1.6.5 VT800 package content	22
1.6.6 VT408 package content	23
1.6.7 VT430 package content	23
1.6.8 VT440 package content	24
1.6.9 VT490 package content	24
1.6.10 VT16 package content	24
1.6.11 VT32 package content	24
1.6.12 VT920 package content	25
1.7 Installation	25
1.7.1 Mounting	25
1.7.2 General connection of sensors and devices	27
1.7.3 Analog sensors connection	27
1.7.4 CAN devices connection	31
1.7.5 AC, DC meters connection	35
1.7.6 Connecting reader	37
1.7.7 Connecting relays	38
1.7.8 Connecting dry contacts boards	39
1.7.8.1 VT16 Dry contacts board mounting	39
1.7.8.2 VT32 Dry contacts board mounting	41
1.7.9 Connecting GSM modem	43
1.7.10 Connecting backup battery	45
1.7.11 Connecting USB camera	46
1.8 Initial Configuration	46
1.8.1 Connecting the device	47
1.8.2 Interface overview	48
1.8.3 User access and permissions	50
1.9 Quick Configuration	53
1.9.1 Network settings	54
1.9.2 Setting up time	55
1.9.3 Creating floor map plan	56
1.9.4 Sensor configuration	58
1.9.5 AC, DC meters configuration	60
1.9.6 Creating groups of elements	61
1.9.7 Creating notifications	62
1.9.8 Creating ping	67
1.9.9 Creating timer	70
1.9.10 Creating Get SNMP element	70
1.9.11 Add IP cam	72
1.9.12 Adding logic schemes	73
1.9.13 Access control	76
1.9.14 Setting up GSM modem	78
1.9.14.1 Setting up GSM modem (v2.0.1 - v2.2.5)	83
1.9.15 Setting up CAN	85
1.9.15.1 Configuring VT408	86
1.9.16 Setting up dynamic DNS	86
1.9.17 Logs export setting	87
1.9.18 Relay switching	87
1.9.18.1 Outlet management in PDU (v2.0.1 - v2.2.5)	89
1.9.19 Saving system logs to SD card	90
1.9.20 Dry contacts settings	92
1.10 Upgrade and restore options	94
1.10.1 HTTP upgrade	95
1.10.2 FTP upgrade	96
1.10.3 Upgrade via USB	96

1.10.4 Restore of appliance	97
1.10.5 Units type programming	100
1.11 Cleaning, battery & fuse disposal and replacement	100
1.11.1 Disposal	101
1.11.2 Battery replacement	101
1.11.3 Fuse replacement	101
1.11.4 Cleaning	102
1.12 Warranty	102
1.12.1 2 year manufacturing warranty	102

Installation and Quick Configuration Manual

This section includes the following:

- Introduction
 - Product description
 - Document overview
 - Related documents
 - Additional options
 - Certificates
- Comparison chart: Master modules
- Comparison chart: Extension unit and CAN modules/sensors
- Comparison chart: Metered power monitoring units
- Physical description
 - Master module panels
 - Modules and sensors panels
 - Previous versions (physical descriptions)
 - (Previous version) Front panel SC81XX
 - (Previous version) Front panel SC8100
 - (Previous version) Back panel SC8100
 - (Previous version) Back panel SC8110
 - (Previous version) Front/back panel SC2100
 - (Previous version) Front/back panel SC408
 - (Previous version) Front/Back panel SC450
 - (Previous version) Front/back panel SC2110
- Inventory
 - VT8101 package content
 - VT8101T package content
 - VT8110 package content
 - VT1808, VT1908 package content
 - VT800 package content
 - VT408 package content
 - VT430 package content
 - VT440 package content
 - VT490 package content
 - VT16 package content
 - VT32 package content
 - VT920 package content
 - Inventory pictures (for admin use)
- Installation
 - Mounting
 - General connection of sensors and devices
 - Analog sensors connection
 - CAN devices connection
 - AC, DC meters connection
 - Connecting reader
 - Connecting relays
 - Connecting dry contacts boards
 - VT16 Dry contacts board mounting
 - VT32 Dry contacts board mounting
 - Connecting GSM modem
 - Connecting backup battery
 - Connecting USB camera
- Initial Configuration
 - Connecting the device
 - Interface overview
 - Interface overview (v2.0.1 - v2.2.5)
 - User access and permissions
 - User access and permissions (v2.0.1 - v2.2.5)
- Quick Configuration
 - Network settings
 - Network settings (v2.0.1 - v2.2.5)
 - Setting up time
 - Settings up time (v2.0.1 - v2.2.5)
 - Creating floor map plan
 - Creating floor map (v2.0.1 - v2.2.5)
 - Sensor configuration
 - Sensor configuration (v2.0.1 - v2.2.5)
 - AC, DC meters configuration
 - Creating groups of elements
 - Creating groups of elements (v2.0.1 - v2.2.5)

- Creating notifications
 - Creating notifications (v2.0.1 - v2.2.5)
- Creating ping
 - Creating ping (v2.0.1 - v2.2.5)
- Creating timer
 - Creating timer (v2.0.1 - v2.2.5)
- Creating Get SNMP element
- Add IP cam
 - Adding IP camera (v2.0.1 - v2.2.5)
- Adding logic schemes
 - Adding logic schemes (v2.0.1 - v2.2.5)
- Access control
 - Access control (v2.0.1 - v2.2.5)
- Setting up GSM modem
 - Setting up GSM modem (v2.0.1 - v2.2.5)
- Setting up CAN
 - Configuring VT408
 - Setting up CAN (v2.0.1 - v2.2.5)
 - Configuring SC460 (v2.0.1 - v2.2.5)
- Setting up dynamic DNS
 - Setting up Dynamic DNS (v2.0.1 - v2.2.5)
- Logs export setting
 - Logs export setting (v2.0.1 - v2.2.5)
- Relay switching
 - Outlet management in PDU (v2.0.1 - v2.2.5)
- Saving system logs to SD card
 - Saving system logs to SD card (v2.0.1 - v2.2.5)
- Dry contacts settings
- Upgrade and restore options
 - HTTP upgrade
 - via HTTP upgrade (v2.0.1 - v2.2.5)
 - FTP upgrade
 - FTP upgrade (v2.0.1 - v2.2.5)
 - Upgrade via USB
 - Restore of appliance
 - Restore of appliance (previous versions)
 - Units type programming
- Cleaning, battery & fuse disposal and replacement
 - Disposal
 - Battery replacement
 - Fuse replacement
 - Cleaning
- Warranty
 - 2 year manufacturing warranty

Introduction

This section includes the following:

- Product description
- Document overview
- Related documents
- Additional options
- Certificates

Product description

Vutlan appliances - monitoring units VT8101, VT8101T, VT8110, VT800, VT1808 and VT1908 - are the main Vutlan modules for monitoring and environmental control. VT8101, VT8101T and VT8110 are used for IP monitoring and environmental control for different premises, whereas VT800 is used for small premises. VT1808 and VT1908 are used for load metering.

Main monitoring systems cannot be connected to each other. Instead, to increase the number of sensors and appliances, extension unit (VT408), embedded modules (VT16, VT920) and CAN modules (VT430, VT440, VT460, VT470, VT490) can be used. Each monitoring unit has embedded software and can be connected to through IP address.

The systems support SNMP protocols. If you need to collect all master modules data in one interface, you can use SNMP software: [Infrastructure monitoring programm](#).

Document overview

The Installation and Quick Configuration Manual describes how to install Vutlan main modules VT8101, VT8101T, VT8110, VT800, VT1808, VT1908 as well as how to connect the modules and to configure the network settings. It shows how to connect and to use extension module VT408, CAN modules and how to mount and use embedded modules VT16, VT920. After performing configuration procedures described in this manual, you can access the system from Firefox, Chrome, IE and Safari mobile and PC browsers, perform additional configuration tasks and begin to monitor the environment.

Vutlan web-interface is built using HTML5. It also uses SVG 1.1 vector format for icons. Only the latest versions of these browsers support it. Please update your browser to the latest version.

Browsers SVG compatibility [can be found here](#).

Browsers HTML5 can be found [here](#).

Related documents

Unless otherwise noted, the following documentation is available on the CD provided with the device or on the web page: www.skycontrol.com. Vutlan User Guide contains all the information on the operation, management, and system setup for one of the following main modules and units: VT8101, VT8101T, VT8110, VT800, VT1808, VT1908, VT408, VT16, VT32, VT920. For support please visit our forum at forum.skycontrol.com. Our documentation pages also include the following: [SNMP manual](#), [Warranty](#), [Charts](#), [NMS integration instructions](#), [Datasheets](#), [Management software](#) and [Drivers](#). For access to our API, please [contact us](#).

developer notes: [linkchange](#)

Additional options

The following options are available for the appliance. For more information on any of these options, contact your Vutlan distributor from which you have purchased Vutlan product.

	Analog sensors	Description	Type
1		DC current meter (VT405)	
2		Current converter (VT406)	
3		Current transmitter (VT407)	
4		DC monitor 0-100V (VT410)	

5		Current loop converter 4-20 mA (VT420)	
2		Temperature sensor (VT500)	
3		Outdoor temperature sensor (VT501)	
4		Humidity sensor (VT510)	
5		AC voltage monitor (VT520)	
6		Access sensor (VT530)	
8		Vibration sensor (VT540). Chain connection possible.	
9		Smoke sensor (VT560). Chain connection possible.	

10	A white, rectangular PIR sensor with a lens and a small opening at the top.	PIR sensor (VT570)	
11	A white, rectangular leak sensor with a cable and a small opening on the side.	Leak sensor (VT590)	
12	A white, rectangular cable leak sensor with a green cable and a small opening on the side.	Cable leak sensor (VT591)	

CAN modules	Description	Type
A black rack control unit with a TR port, CAN1 and CAN2 ports, and a blue button.	Rack control unit (VT430)	Access, dry contacts, temperature, humidity
A black dry contacts unit with a green terminal block.	Dry contacts unit (VT440)	Dry contacts

CAN sensors	Description	Type
A white, cylindrical smoke, humidity and temperature CAN sensor.	Smoke, humidity and temperature CAN sensor (VT460)	
A white, rectangular PIR, vibration, temperature CAN sensor.	PIR, vibration, temperature CAN sensor (VT470)	

	Humidity and temperature CAN sensor (VT490)	
--	---	--

Embedded modules	Description	Type
	Dry contacts PCB (VT16)	
	Dry contacts PCB (VT32)	
	GSM modem (VT920)	

Extension unit	Description	Type
	Sensor unit (VT408)	Analog, CAN

AC/DC meters	Description	Тип
	Shunt 100A (VT100)	
	DC current transducer 100A (HOS-100Q1)	

	DC current transducer 100A(HOS-100Q11)	
	AC current transducer 100A 100A (HAT-100Q1)	

Certificates

All Vutlan products are [CE](#), [RohS](#) and [EMC](#) compatible. The CE marking is the manufacturer's declaration that the product meets the requirements of the applicable EC directives. RohS ensures that we do not use certain hazardous materials in the manufacture of our electronic and electrical equipment. EMC aims to ensure that equipment items or systems will not interfere with or prevent each other's correct operation through spurious emission and absorption of EMI.

[EMC certificate.](#)

Comparison chart: Master modules

Vutlan master module comparison chart

VT800, VT8110, VT8101, VT1808 and VT1908 are master modules and cannot connect to each other. For scalability please use extension modules and embedded modules.

- Built-in
- None
- Extension
- Not extendable

Remote Control	VT8101	VT8101T	VT8110	VT800
Device Management: Web, SNMP, manually via SMS	●	●	●	●
Interface & Protocol support	VT8101	VT8101T	VT8110	VT800
Interface: Access via Internet browsers Firefox, Chrome and Safari. IE is not supported.	●	●	●	●
LAN: Ethernet 10/100 Mbit	●	●	●	●
Network protocols: DHCP, HTTP, HTTPS, SNMP, SMTP, SSL, FTP, Syslog, CAN	●	●	●	●
OS: Linux 2.6.38	●	●	●	●
RAM: 64Mb	●	●	●	●
ROM: 128Mb FLASH	●	●	●	●
Software: Built-in software for events processing.	●	●	●	●
Alert types: FTP, Syslog, SMTP or SNMP, SMS (GSM modem is ordered separately)	●	●	●	●

Pings: Built-in function for ping	•	•	•	•
LEDs: 4 green: ACT, CN1, CN2, ERR	•	•	•	•
LEDs: Latching relays	3+1	3+1	4	□
Clock: Built-in clock with time synchronization	•	•	•	•
Watchdog: Built-in watchdog timer	•	•	•	•
Power	VT8101	VT8101T	VT8110	VT800
Power input: 12V. Fuse at the inlet.	□	□	□	•
Power input: 240V	C14	□	C14	□
DC power: 24-48V	□	•	□	□
Fuse: Fuse at the inlet	2A	□	10A	□
Output voltage: 240V	□	□	4 * C13	□
Max. power consumption:	22W	22W	22W	22W
Max. total load current:	□	□	10A	□
The maximum current load on the relay:	10A	10A	10A	□
Power reservation: 12V, built-in voltage monitor, voltage range 9-12.6V.	•	•	•	□
Inlets/Outlets	VT8101	VT8101T	VT8110	VT800
Ethernet: 100Mbit	•	•	•	•
USB: USB 2.0	•	•	•	•
Mini USB AB: USB 2.0 HS	•	•	•	•
Analog port: 6P4C for connection of any analog sensor.	8	8	8	1
CAN BUS: 2 x 6P6C for connection of up to 8 CAN sensors on each BUS. Fuse protection on each line.	•	•	•	•
Relay outputs: latching relays 240V*10A	3	3	□	□
Alarm relay output: 12V	1	1	□	□
Power output: latching relays 240V*10A	□	□	4	□
Power metering: up to 240V*10A	□	□	□	□
Reader: I-Touch button or proximity reader	•	•	•	•
External Memory	VT8101	VT8101T	VT8110	VT800
SD, SDHC card:	SD	SD	SD	SD
Scalability (modules are ordered separately)	VT8101	VT8101T	VT8110	VT800
Extension module SC408, CAN units and sensors: Allows to increase the number of sensors in the system. It is possible to connect up to 8 CAN sensors and / or 8 modules to one CAN bus.	•	•	•	•
Dry contacts module SC16: Built-in into the master module.	•	•	•	•
GSM modem SC920: Built-in into the master module.	•	•	•	•
Environmental characteristics	VT8101	VT8101T	VT8110	VT800

Operating temperature: 0 to 60 °C	•	•	•	•
Storage temperature: -25 to 85 °C	•	•	•	•
Operating humidity: 0 to 90 %, non-condensing	•	•	•	•
Storage humidity: 0 to 95 %, non-condensing	•	•	•	•
Other Features				
	VT8101	VT8101T	VT8110	VT800
Installation:	19"	19"	19"	Desktop
Dimensions (L x W x H) in mm:	440*44*75	440*44*75	440*44*77	260*44*75
Weight:	1,8 kg	1,8 kg	1,9 kg	1,2 kg

- Built-in None • Extension Not extendable

Comparison chart: Extension unit and CAN modules/sensors

Vutlan extension unit and CAN modules/sensors comparison chart

All Vutlan master modules allow connection of extension units and CAN modules/sensors through CAN ports. It is possible to connect up to 8 CAN sensors/units to one CAN bus.

- Built-in None

Power	VT408	VT430	VT440	VT460	VT470	VT490
Power input: 12V. Recommended to use at all times.	•	<input type="checkbox"/>	<input type="checkbox"/>	<input type="checkbox"/>	<input type="checkbox"/>	<input type="checkbox"/>
Power over CAN: Possible if only a few module are in a chain (or first in a chain of 2 or 3 sensors).	•	•	•	•	•	•
Inlets/Outlets						
	VT408	VT430	VT440	VT460	VT470	VT490
Analog: 8*6P4C for connection of analog sensors	•	<input type="checkbox"/>	<input type="checkbox"/>	<input type="checkbox"/>	<input type="checkbox"/>	<input type="checkbox"/>
CAN: 2*6P6C for connection of up to 8 CAN sensors on each BUS. Fuse protection on each line.	•	•	•	•	•	•
PIR sensor: for rack door control.	<input type="checkbox"/>	•	<input type="checkbox"/>	<input type="checkbox"/>	<input type="checkbox"/>	<input type="checkbox"/>
PIR sensor: for motion detection.	<input type="checkbox"/>	<input type="checkbox"/>	<input type="checkbox"/>	<input type="checkbox"/>	•	<input type="checkbox"/>
Vibration sensor:	<input type="checkbox"/>	<input type="checkbox"/>	<input type="checkbox"/>	<input type="checkbox"/>	•	<input type="checkbox"/>
Dry contacts:	<input type="checkbox"/>	2	32 / 64	<input type="checkbox"/>	<input type="checkbox"/>	<input type="checkbox"/>
Humidity sensor:	<input type="checkbox"/>	•	<input type="checkbox"/>	•	<input type="checkbox"/>	<input type="checkbox"/>
Temperature sensor:	<input type="checkbox"/>	<input type="checkbox"/>	<input type="checkbox"/>	•	•	<input type="checkbox"/>
Smoke sensor:	<input type="checkbox"/>	<input type="checkbox"/>	<input type="checkbox"/>	•	<input type="checkbox"/>	<input type="checkbox"/>
Airflow heat sensors: Response time 2 min, recovery time 1 min; Temperature measurement range -40 ... +100 ° C, accuracy 2 ° C	<input type="checkbox"/>	<input type="checkbox"/>	<input type="checkbox"/>	<input type="checkbox"/>	<input type="checkbox"/>	<input type="checkbox"/>
Other Features						
	VT408	VT430	VT440	VT460	VT470	VT490
Installation: Desktop	•	<input type="checkbox"/>	•	<input type="checkbox"/>	<input type="checkbox"/>	•
Installation: Wall, Ceiling	•	•	•	•	•	•
Installation: Mounting bracket supplied	<input type="checkbox"/>	•	•	•	•	<input type="checkbox"/>
Dimensions (L x W x H) in mm:	110×68×40	89x36x27	215×40×40	Ø100×45	105×57×40	68*47*26

Weight:	0.6 kg	0.5 kg	0.5 kg	290 g	130 g	100 g
---------	--------	--------	--------	-------	-------	-------

- Built-in None

Comparison chart: Metered power monitoring units

Each outlet metering units are used for load measuring (VT1808) and/or allows to switch on/off or reboot up to 8 different loads (VT1908).

It is possible to connect some sensors and mount GSM modem.

Main advantages:

Bistable relays 16A

Switching of outlets on/off

Current and voltage measure

Monitoring of sensors

EMC digital bus

Outlets C13

Built-in HTTP, HTTPs interface

Built-in SNMP v.1, v.2c, v.3

GSM modem

Emergency and / or alternate shutdown

Simple installation and easy connection

Configurable logic of switching

Bistable relays in conjunction with possible power reservation 12V using a battery, allows the system to compensate for short-term voltage dips (220-240V) without changing the position of the relays.

Programmable logic allows to specify the use of consecutive or one-time mode for inclusion of electric loads. Consecutive inclusion with programmable delay of electric loads reduces starting current.

Panel of remote management functions:

Units comparison chart

VT1808 (metered) and VT1908 (managed) are master modules and cannot connect to each other. For scalability please use extension modules and embedded modules.

- Built-in None
- Extension Not extendable

Remote Control	VT1808	VT1908
Description:	Metered	Managed
Device Management: Web, SNMP, manually via SMS	•	•
Interface & Protocol support	VT1808	VT1908
Interface: Access via Internet browsers Firefox, Chrome and Safari. IE is not supported.	•	•
LAN: Ethernet 10/100 Mbit	•	•
Network protocols: DHCP, HTTP, HTTPS, SNMP, SMTP, SSL, FTP, Syslog, CAN	•	•
OS: Linux 2.6.38	•	•
RAM: 64Mb	•	•
ROM: 128Mb FLASH	•	•
Software: Built-in software for events processing.	•	•
Alert types: FTP, Syslog, SMTP or SNMP, SMS (GSM modem is ordered separately)	•	•
Pings: Built-in function for ping	•	•
LEDs: 4 green: ACT, CN1, CN2, ERR	•	•

Relais: Latching	•	•
Clock: Built-in clock with time synchronization (NTP)	•	•
Watchdog: Built-in watchdog timer	•	•
Power	VT1808	VT1908
Power input:	200-240VA 50-60 Hz	200-240VA 50-60 Hz
Input:	C20 16A	C20 16A
Circuit Breakers: on inlet	2 * 10A	2 * 10A
Output voltage: 220-240V	8*10A	8*10A
Power consumption: 6W-18W	•	•
Max. load:	6 kW	6 kW
Power measuring: Input voltage sensor, current sensors for each outlet	•	•
Power reservation: Built-in voltage monitor, power reservation battery 9-11V connection possible.	•	•
Inlets/Outlets	VT1808	VT1908
Ethernet: 100Mbit	•	•
USB: USB 2.0	•	•
Mini USB AB: USB 2.0 HS	•	•
Analog port: 6P4C for connection of any analog sensor.	1	1
CAN BUS: 2 x 6P6C for connection of up to 8 CAN sensors on each BUS.	•	•
Power output: Latching relays 220-240V*16A with LEDs indication on front panel	□	8
Outlets: IEC 320 C13*10A	8	8
External Memory & Surveillance	VT1808	VT1908
SD card:	MicroSD	MicroSD
USB camera: Linux UVC Webcam with MJPEG format support, HS USB connected.	•	•
Scalability (these modules and sensors are ordered separately)	VT1808	VT1908
Extension modules and CAN sensors: up to 8 devices on one CAN bus.	•	•
GSM modem VT920: Built-in into the master module.	•	•
Analog sensor:	•	•
Environmental characteristics	VT1808	VT1908
Operating temperature: 0 to 60 °C	•	•

Storage temperature: -25 to 85 °C	•	•
Operating humidity: 0 to 90 %, non-condensing	•	•
Storage humidity: 0 to 95 %, non-condensing	•	•
Other Features	VT1808	VT1908
Description:	Metered	Managed
Installation:	19"	19"
Dimensions (L x H x D) in mm:	440*44*122	440*44*122
Weight:	2,3 kg	2,3 kg

- Built-in □ None • Extension Not extendable

Physical description

This section includes the following:

- Master module panels
- Modules and sensors panels
- Previous versions (physical descriptions)
 - (Previous version) Front panel SC81XX
 - (Previous version) Front panel SC8100
 - (Previous version) Back panel SC8100
 - (Previous version) Back panel SC8110
 - (Previous version) Front/back panel SC2100
 - (Previous version) Front/back panel SC408
 - (Previous version) Front/Back panel SC450
 - (Previous version) Front/back panel SC2110

Master module panels

VT8101 front and back panel

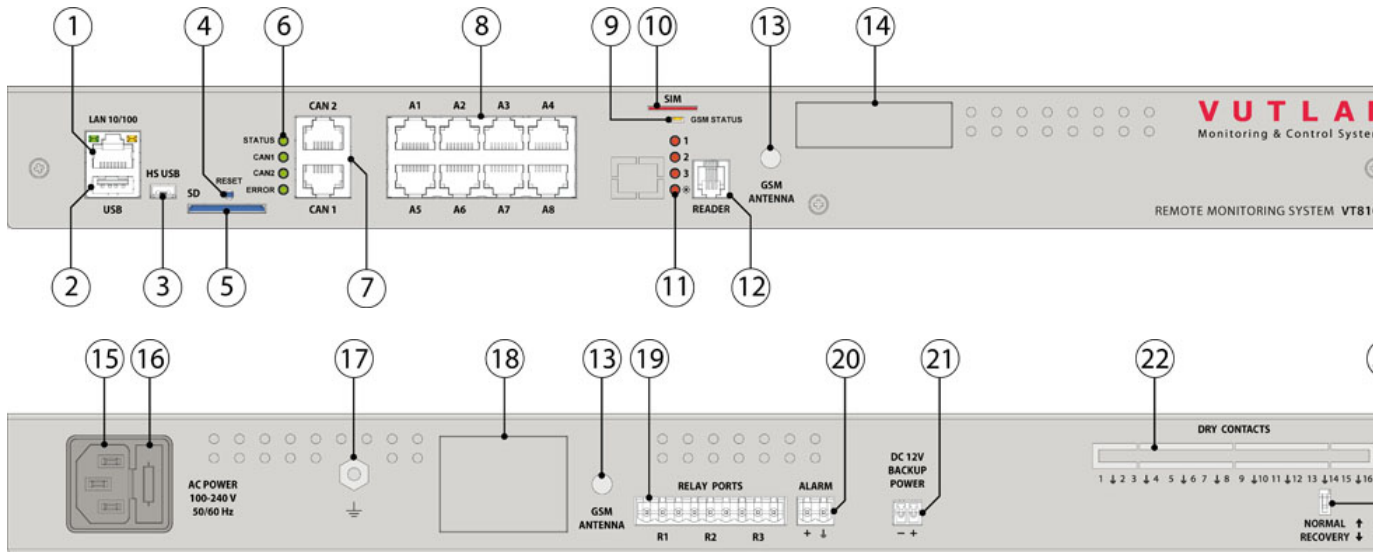

VT8101T front and back panel

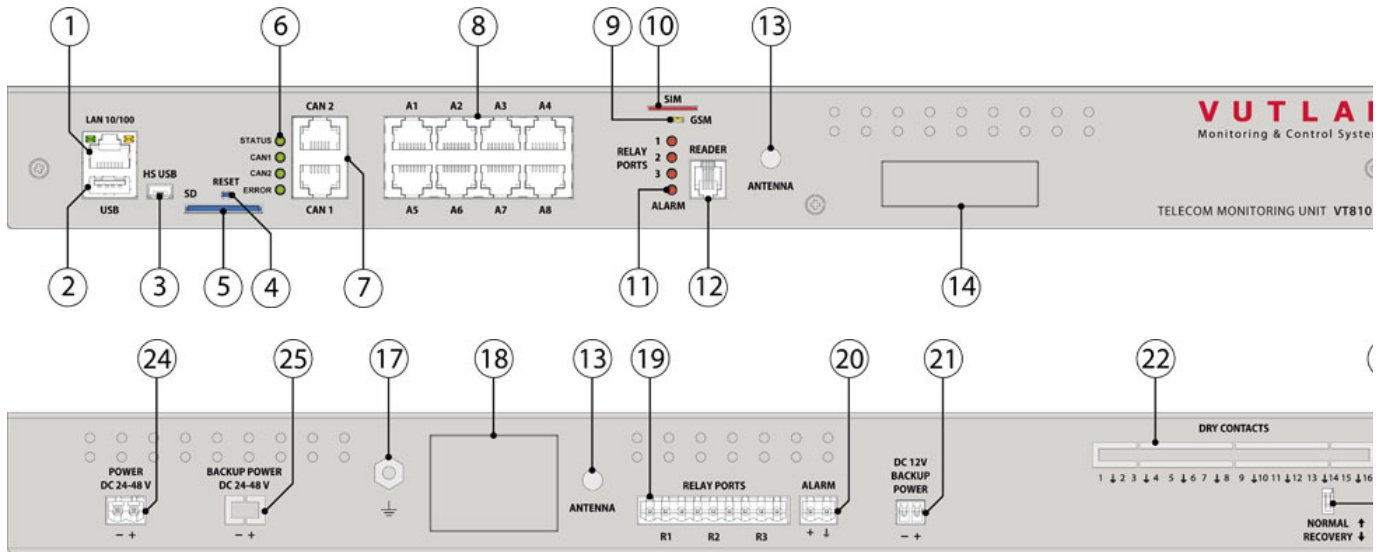

VT8110 front and back panel

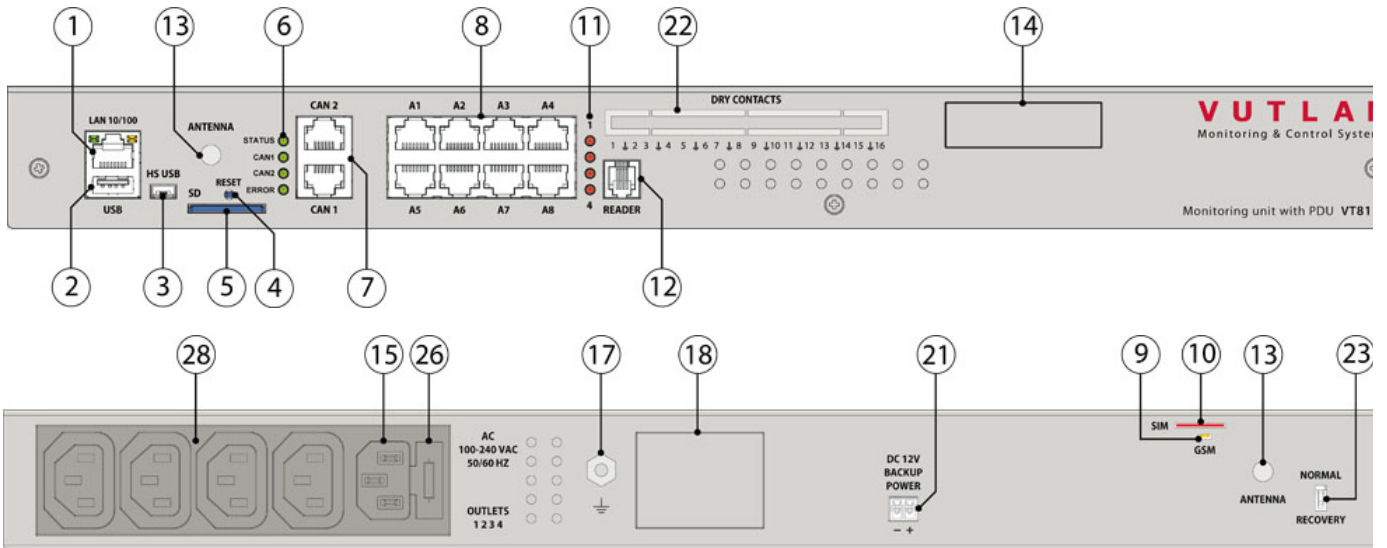

VT800 front and back panel

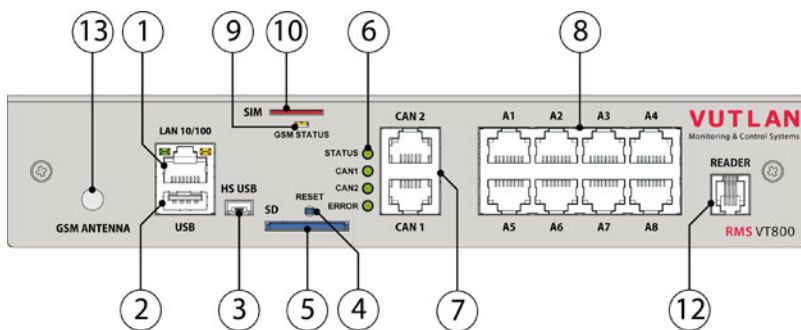

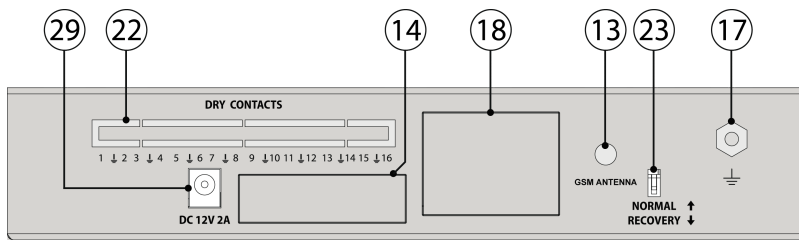

VT1808 front and back panel

VT1908 front and back panel

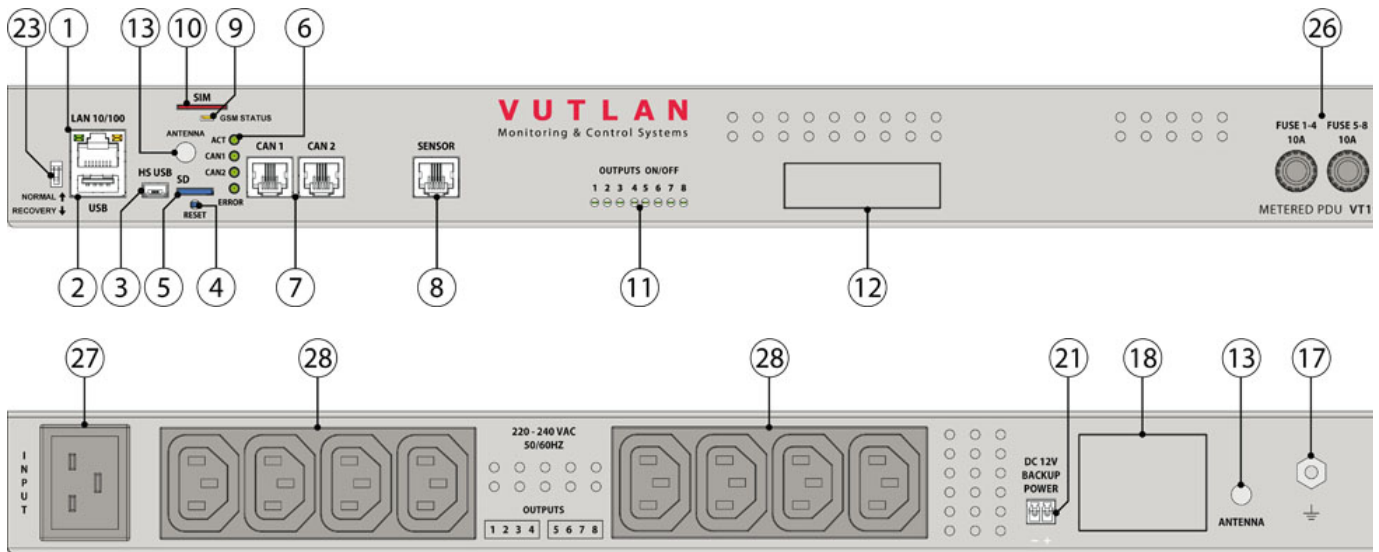

1. "LAN" - Ethernet 10/100 Base-T port, provides Ethernet connection.

- LEDs - "yellow" (status) and "green" (traffic) shows the network traffic. The status LED: flashes green when system starts up, shows the connection state (constant green light - the connection is established, blinking green - the connection attempt).

2. "USB" - type A USB-port 2.0, is required for USB flash drive to upgrade an appliance.

3. "HS" - type miniAB USB-port 2.0, required to connect a USB camera or to restore an appliance.

4. "Reset" - resets the appliance.

5. "SD" - SD, MicroSD card connector with ejector, needed to store data.

6. LEDs: "ACT" - indicates appliance status, "CN1" - indicates CAN1 bus traffic, "CN2" - indicates CAN2 bus traffic, "ERR»" - indicates error and traffic.

- Blinking "ACT"
- Blinking "CN1"
- Blinking "CN2"
- Blinking "ERR»"

7. "CAN" - two equivalent digital connectors RJ12 for the connection of CAN sensors and CAN extensions on a CAN bus, with auto-sensing.

8. "A1..A8" - 8 RJ12 analog sensor inputs with auto-sensing.

9. LED: "ACT" - indicates GSM SIM card status

10. "SIM" - connector with an ejector, used when GSM modem is installed inside of the appliance to connect SIM card.

11. "Output LEDs" - relays status indicators, "LED * " - Alarm status indicator

12. "Reader" - RJ9 connector for IButton Proximity or I-Touch readers with auto-sensing.

13. "SMA" - connector, used when GSM modem is installed inside of the appliance to connect GSM antenna.
 14. "Sticker" - Place for a sticker that can be written on. For example: you can write an IP address of master module.
 15. "AC line" - power input 240V 10A. IEC C14 connector (AC 100-240 VAC, 50/60HZ).
 16. "Fuse 2A" - type 5*20mm
 17. " " Grounding.
 18. "S/N" - serial number. You will need this serial number if you want to contact our support team. It is important that you do not lose it!
- "Sensor" - RJ12 analog sensor input with auto-sensing.
19. "RLY1...RLY3" - 3 relays 9 pin output terminal. The relays maximum power output - 10A * 240V.
 20. "Alarm" - 12V 0.2A output terminal
 21. "DC 12V" - backup power socket, to connect a battery or a power backup.
 22. "Dry contacts" - empty slot for dry contacts module VT16, used to connect dry contacts on doors, windows, etc.
 23. "Dip switch" Normal Off - the system should be always switched to this mode.
- Recovery On - use this option only in case you need to recover manufacturing settings.
24. "DC power 24-48V" - power socket.
 25. "DC power 24-48V" - power backup socket. Possible only in version VT8101T2.
 26. "Fuse 10A" - type 5*20mm
 27. "INPUT" - Power input 240V 16A. IEC C20 connector (AC 100-240 VAC, 50/60HZ).
 28. "PWR" - Power outputs (AC 100-240 VAC, 50/60HZ).
 29. "DC 12V 2A" - DC power input.

Modules and sensors panels

CAN sensors:

VT430 / Rack control unit

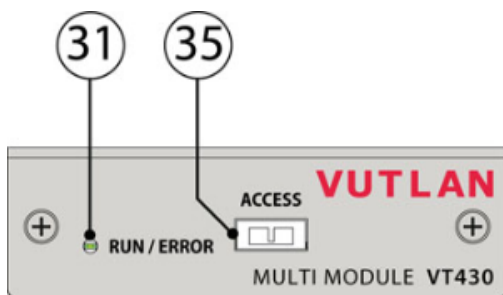
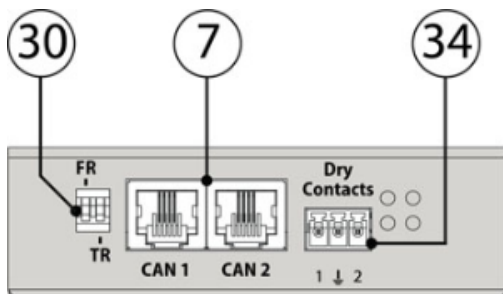

VT440/ Dry contacts unit

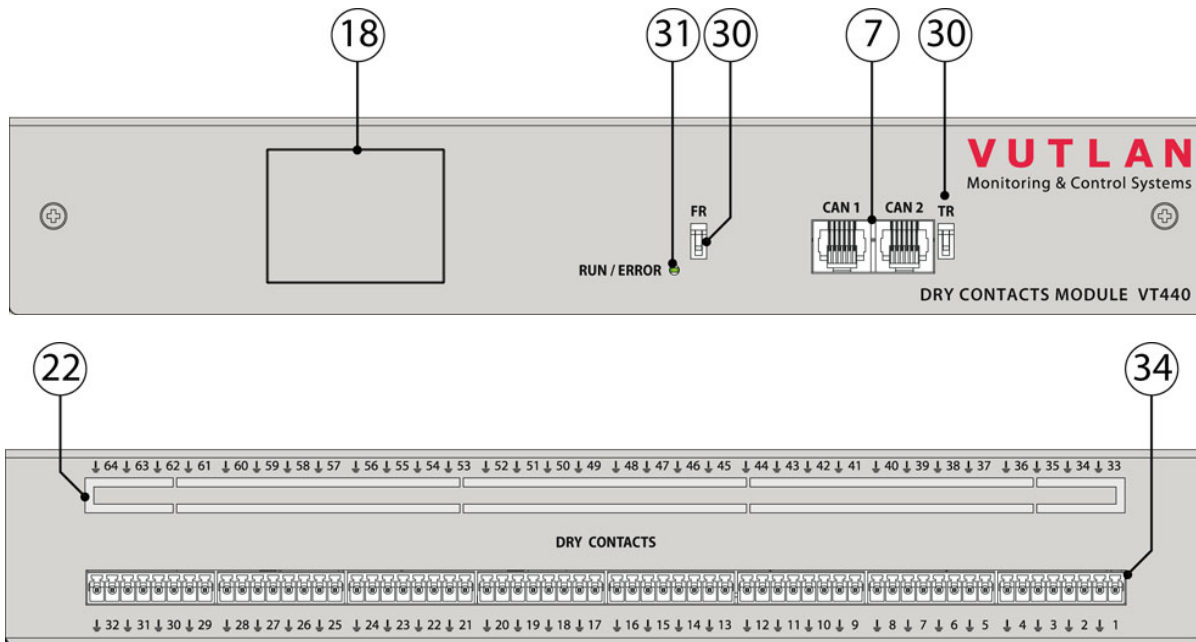

AC,DC meters:

VT406 / Converter

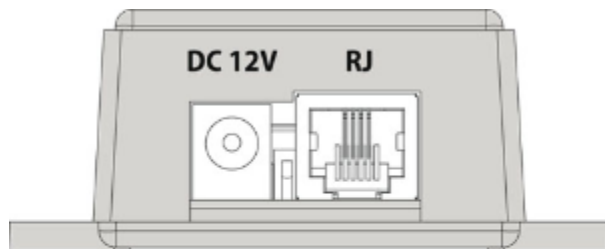

DC 12V	OUTPUT 0..+5V
--------	---------------

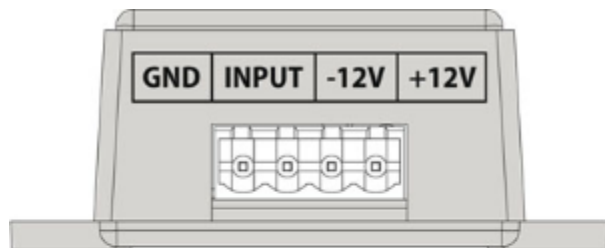

VT406

GND	INPUT	POWER OUTPUT	
		-4..+4V	-12V +12V

VT407 / Converter

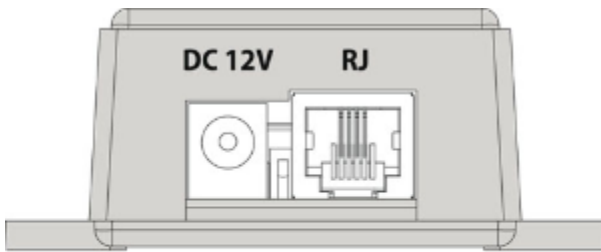

DC 12V	OUTPUT 0..+5V
--------	---------------

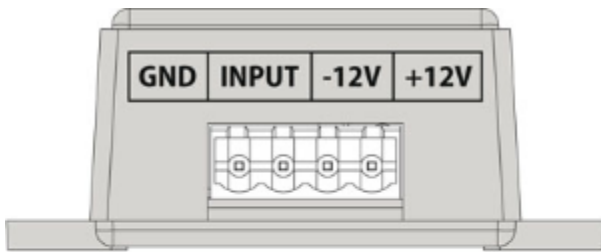

VT407

GND	INPUT 0..+5V	POWER OUTPUT	
		-12V	+12V

Extension units:

VT408 / Sensor module

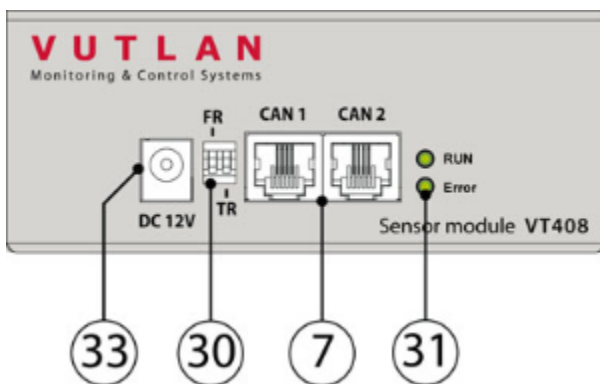

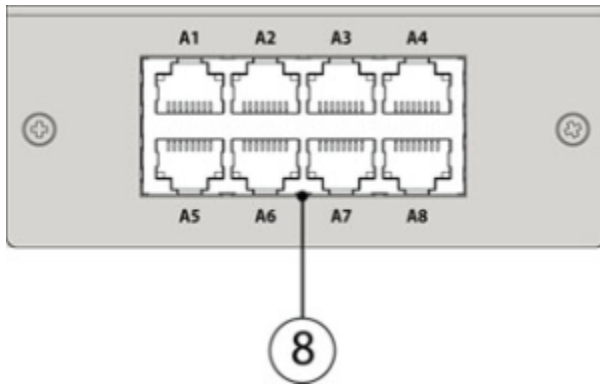

- 7. "CAN" - two equivalent digital connectors RJ12 for the connection of CAN sensors and CAN extensions on a CAN bus, with auto-sensing.
- 8. "A1..A8" - 8 RJ12 analog sensor inputs with auto-sensing.
- 18. LED: "ACT" - indicates GSM SIM card status
- 22. "33...64" - Dry contacts empty slot.
- 30. "TR" - Terminator (nearest to CAN connectors).
- 31. "LEDs" - CAN unit status indicator.
- 33. "DC 12V" - DC power input 12V 0.5A.
- 34. "1...32" - Dry contacts terminal.
- 35. "Access" - Door IR access sensor.

Inventory

This section includes the following:

- [VT8101 package content](#)
- [VT8101T package content](#)
- [VT8110 package content](#)
- [VT1808, VT1908 package content](#)
- [VT800 package content](#)
- [VT408 package content](#)
- [VT430 package content](#)
- [VT440 package content](#)
- [VT490 package content](#)
- [VT16 package content](#)
- [VT32 package content](#)
- [VT920 package content](#)
- [Inventory pictures \(for admin use\)](#)

VT8101 package content

Make sure that the contents of the delivery meet the following configuration. Report a missing or damaged component to your supplier. If damage occurred during transportation, contact the appropriate delivery service.

	Package content	Description
1		Monitoring unit VT8101.
2		19" rack brackets - 2 pcs.
3		M3 x 8 Phillips flat-head screws - 6 pcs.
4		Relay terminal plug 9 x 5.00 mm - 1 pcs
5		Relay terminal plug 5.08 mm - 1 pcs
6		1.8-m EU Schuko C13 0.5 MM ² power cord
7		RJ-45 1m patch cable
8		USB-MiniUSB cable
9		Self-adhesive rubber foot - 4 pcs
10		Backup battery 3.5mm terminal plug
11		CD-ROM with documentation and software
12		Configuration manual
13		Warranty card

VT8101T package content

Make sure that the contents of the delivery meet the following configuration. Report a missing or damaged component to your supplier. If damage occurred during transportation, contact the appropriate delivery service.

	Package content	Description
1		Monitoring unit VT8101.
2		19" rack brackets - 2 pcs.
3		M3 x 8 Phillips flat-head screws - 6 pcs.
4		Relay terminal plug 9 pins, 5.00 mm - 1 pcs
5		Power terminal plug 5.08 mm - 3 pcs
6		RJ-45 1m patch cable
7		USB-MiniUSB cable
8		Self-adhesive rubber foot - 4 pcs
9		Backup battery 3.5 mm terminal plug
10		CD-ROM with documentation and software
11		Configuration manual
12		Warranty card

VT8110 package content

Make sure that the contents of the delivery meet the following configuration. Report a missing or damaged component to your supplier. If damage occurred during transportation, contact the appropriate delivery service.

Комплектующие	Описание
---------------	----------

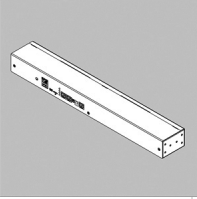
1		Monitoring unit VT8110
2		19" rack brackets - 2 pcs
3		M3 x 8 Phillips flat-head screws - 6 pcs
4		1.8-m EU Schuko C13 0.75 mm ² power cord
5		RJ45 1m patch cable
6		USB-miniUSB cable
7		Self-adhesive rubber foot - 4 pcs
8		Backup battery 3.5mm terminal plug
9		CD-ROM with documentation and software
10		Manual
11		Warranty card

VT1808, VT1908 package content

Make sure that the contents of the delivery meet the following configuration. Report a missing or damaged component to your supplier. If damage occurred during transportation, contact the appropriate delivery service.

	Package content	Description
1		Metered monitoring unit.
2		19" rack brackets - 2 pcs.
3		M3 x 8 Phillips flat-head screws - 6 pcs.
4		1.8-m EU Schuko C19 1 mm ² power cord - 1 pcs
5		RJ-45 1m patch cable
6		USB-MiniUSB cable
7		Self-adhesive rubber foot - 4 pcs
8		Backup battery 3.5mm terminal plug
9		CD-ROM with documentation and software
10		Configuration manual
11		Warranty card

VT800 package content

Make sure that the contents of the delivery meet the following configuration. Report a missing or damaged component to your supplier. If damage occurred during transportation, contact the appropriate delivery service.

	Package content	Description
--	-----------------	-------------

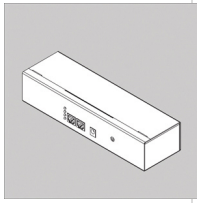
1		Monitoring unit VT800.
2		12V adapter.
3		19" rack brackets - 2 pcs.
4		M3 x 8 Phillips flat-head screws - 6 pcs.
5		RJ-45 1m patch cable
6		USB-MiniUSB cable
7		Self-adhesive rubber foot - 4 pcs
8		CD-ROM with documentation and software
9		Configuration manual
10		Warranty card

VT408 package content

Make sure that the contents of the delivery meet the following configuration. Report a missing or damaged component to your supplier. If damage occurred during transportation, contact the appropriate delivery service.

	Package content	Description
1		Extension unit VT408.
2		RJ11 6P4C 2m CAN cable.
3		Self-adhesive rubber feet - 4 pcs.
4		12V adapter.

VT430 package content

Make sure that the contents of the delivery meet the following configuration. Report a missing or damaged component to your supplier. If damage occurred during transportation, contact the appropriate delivery service.

	Package content	Description
1		Rack control unit VT430.
2		RJ11 6P4C 2m CAN cable
3		Self-adhesive rubber foot - 4 pcs
5		Screws M6 - 2 pcs (addchange)
6		Square nuts M6 - 2 pcs (addchange)
7		Terminal 3.5 mm - 1 pcs (addchange)
8		Bracket - 1 pcs (addchange)
9		White sticker - 1 pcs

VT440 package content

Make sure that the contents of the delivery meet the following configuration. Report a missing or damaged component to your supplier. If damage occurred during transportation, contact the appropriate delivery service.

	Package content	Description
1		Dry contacts unit VT440.
2		RJ11 6P4C 2m cable
3		Self-adhesive rubber foot - 4 pcs
4		Terminal 6*3.5 mm - 8 pcs (addchange)
5		Screws M3*8 - 6 pcs
6		19" rack brackets - 2 pcs.

VT490 package content

Make sure that the contents of the delivery meet the following configuration. Report a missing or damaged component to your supplier. If damage occurred during transportation, contact the appropriate delivery service.

	Package content	Description
1		Sensor unit VT490.
2		RJ11 6P4C 2m phone cable
3		Self-adhesive rubber feets - 4 pcs.
4		Terminal 6*3.5 mm - 8 pcs
5		Screws M4 x 10 - 2 pcs
6		19" rack brackets - 2 pcs.
7		Screws 3,9 x 9,5 - 2 pcs
8		Nuts M4 - 2 pcs

VT16 package content

Make sure that the contents of the delivery meet the following configuration. Report a missing or damaged component to your supplier. If damage occurred during transportation, contact the appropriate delivery service.

	Package content	Description
1		Dry contacts board
2		BH10 cable
3		Terminal plugs 6pins, 3.5 mm - 4 pcs
5		Screws M3*5 mm - 3 pcs.

VT32 package content

Make sure that the contents of the delivery meet the following configuration. Report a missing or damaged component to your supplier. If damage occurred during transportation, contact the appropriate delivery service.

	Package content	Description
1		Dry contacts board
2		BH10 cable
3		Terminal plugs 6*3.5 mm - 8 pcs
5		Screws M3*5 mm - 3 pcs.

VT920 package content

Make sure that the contents of the delivery meet the following configuration. Report a missing or damaged component to your supplier. If damage occurred during transportation, contact the appropriate delivery service.

	Package content	Description
1		GSM modem board.
2		BH16 cable.
3		Antenna GSM SMA
4		Antenna wire with spacers
5		Screws M3*5 mm - 3 pcs.

Installation

This section includes the following:

- [Mounting](#)
- [General connection of sensors and devices](#)
- [Analog sensors connection](#)
- [CAN devices connection](#)
- [AC, DC meters connection](#)
- [Connecting reader](#)
- [Connecting relays](#)
- [Connecting dry contacts boards](#)
 - [VT16 Dry contacts board mounting](#)
 - [VT32 Dry contacts board mounting](#)
- [Connecting GSM modem](#)
- [Connecting backup battery](#)
- [Connecting USB camera](#)

Mounting

The units (VT8101, VT8110, VT800, VT1808 and VT1908) can be installed in the front or rear of the rack. It takes up to 1U of 19" rack! Unit VT800 can be installed on the wall or on desktop. All units can be put on the shelf using self-adhesive rubber feet.

When installing, consider the following conditions:

Connect the unit only after checking the grounding of the circuit.

Do not connect homemade sensors and devices with unknown functions to the unit!

You must install the unit in place, where the ambient temperature corresponds to the values listed under "Specifications". Keep in mind that the temperature of the unit increases in cramped conditions, please keep track of the temperature on the internal temperature sensor. Try to install the unit in such a way as to allow for normal air

circulation required for the normal functionality of the unit.

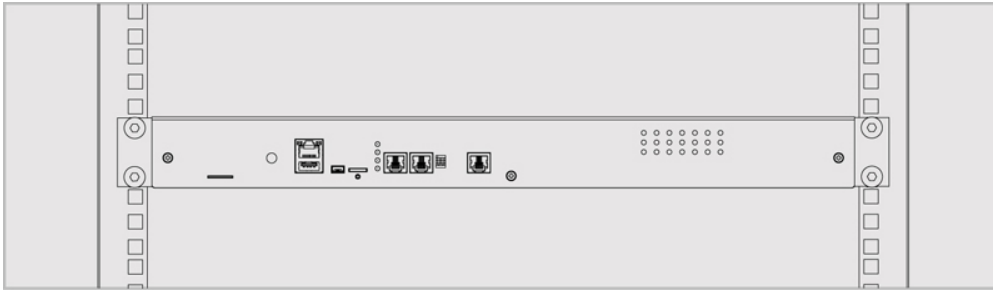

Rack mount

When installing the unit in a 19" rack, make sure that there is no uneven mechanical loading so as not to create a dangerous situation. You should not use the unit as a shelf or hang it uncommitted.

Select a place of unit installation inside the rack. The system takes up 1U of rack. Set to the desired location and tighten the bolts on the spacer nuts.

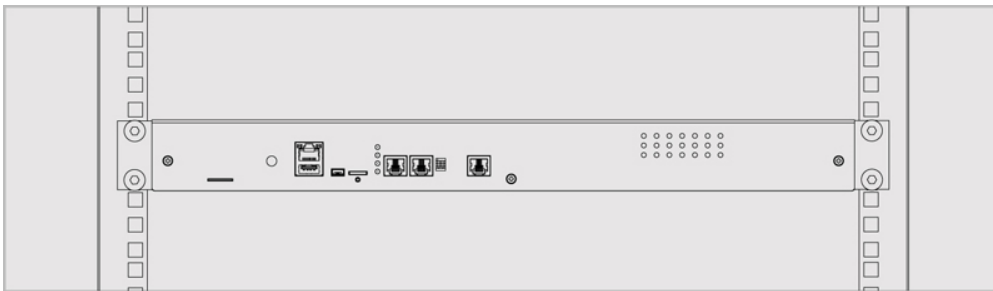

To avoid equipment damage fasten all the screws all the way!

Wall mount

Use the following diagrams for dimension references for wall mount.

VT800 mini-master module:

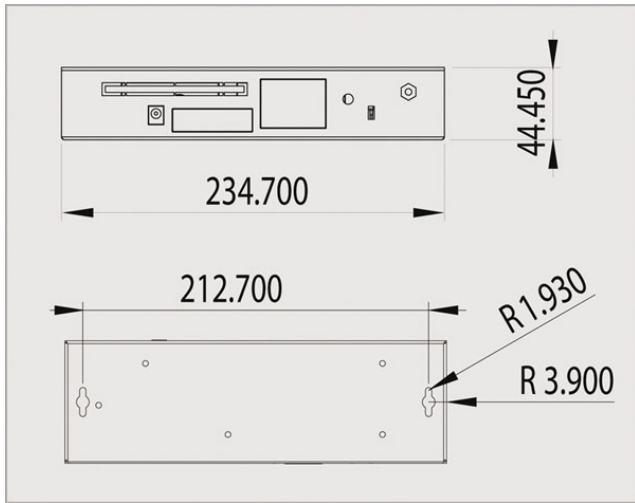

To avoid equipment damage fasten all the screws all the way!

Power cable and Network cable connection

Before applying power to the device, read its electrical characteristics in order to avoid the power supply circuit overloading.

Do not connect the device to ungrounded outlets! Check the outlet and make sure they are grounded when using the extension cords.

1. For VT8101, VT8110, VT1808 and VT1908, connect the appropriate power cord to the unit AC line input. For VT800 plug in the power adapter that was in the package content.
2. Connect unit's Ethernet port using network cable to the switch.
3. Plug the power cable into the power source.

General connection of sensors and devices

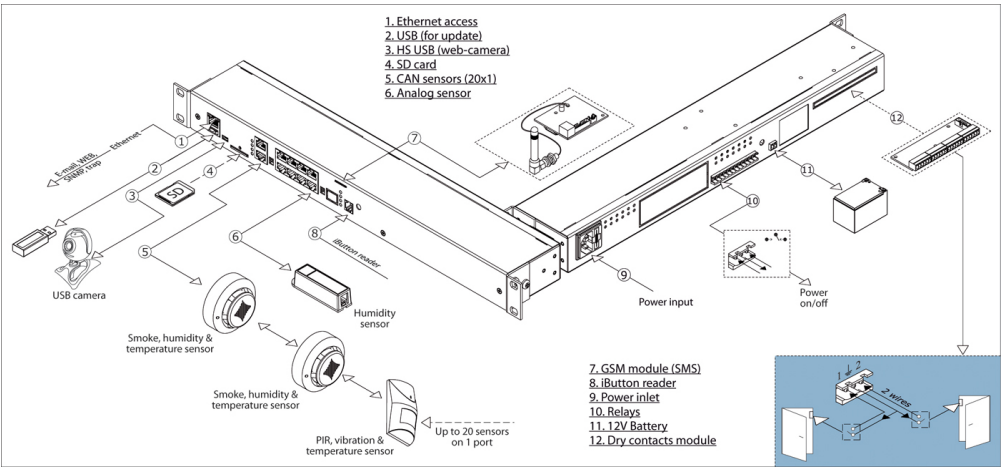

developer notes: change picture (addchange)

Analog sensors connection

Analog sensors connection

Connect analog sensor by a supplied RJ-11 (6P4C) cable to any analog port "A1 .. A8" or "Sensor" port. Determination of the sensor type and connection will occur automatically.

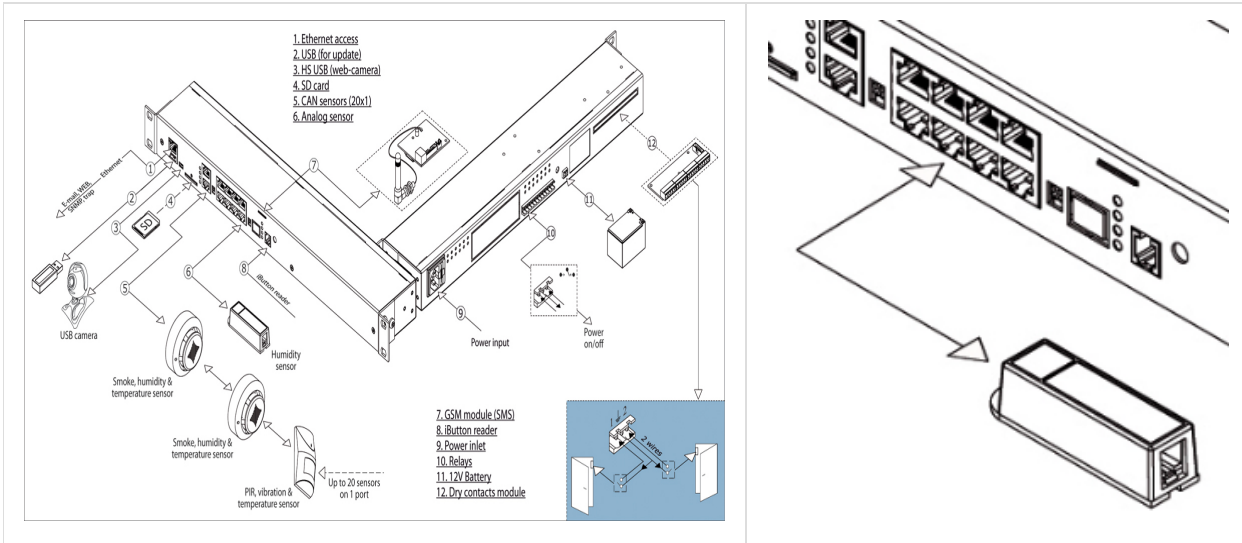

developer notes: change picture (addchange)

This procedure applies to the following sensors, which are supported by the appliance and are connected to the analog ports:

	Analog sensors	Daisy chain
1	Temperature sensor (VT500)	<input type="checkbox"/>
2	Outdoor temperature sensor (VT501)	<input type="checkbox"/>
3	Humidity sensor (VT510)	<input type="checkbox"/>
4	AC Voltage detector (VT520)	<input type="checkbox"/>
5	Access sensor (VT530)	<input type="checkbox"/>
6	Vibration sensor (VT540)	<input type="checkbox"/>
7	Smoke sensor (VT560)	<input type="checkbox"/>
8	PIR sensor (VT570)	<input type="checkbox"/>
9	Leak sensor (VT590)	<input type="checkbox"/>
10	Cable leak sensor (VT591)	<input type="checkbox"/>

If strong electromagnetic interferences are present, we recommend to use 3-pair cable CAN FTP for sensor connection!

Chain connection of VT530, VT540, VT560

VT530, VT540 and VT560 are the only analog sensors that allow nonaddressable chain connection. All the sensors in one chain are seen by the system as one sensor. One chain can have up to 10 sensors. Example of such connection:

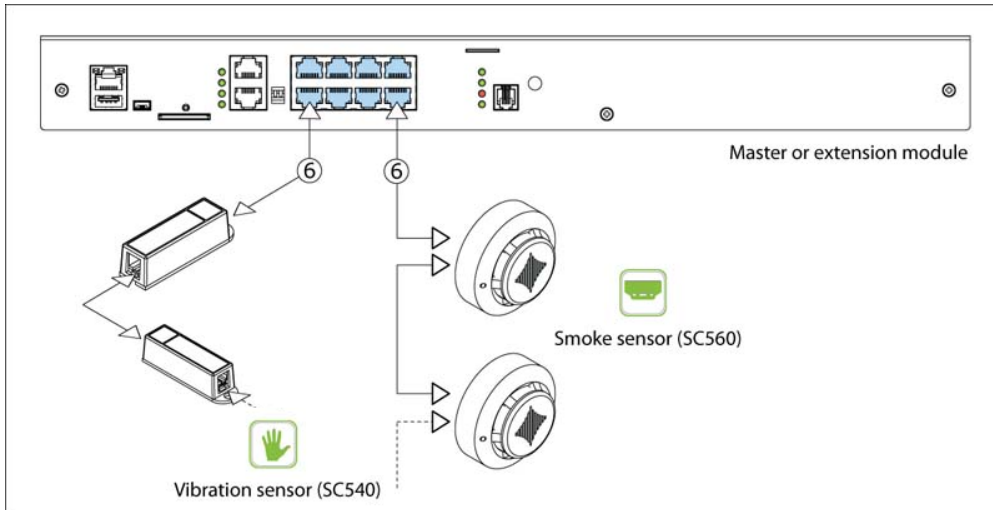

developer notes: change picture (addchange)

Connecting analog sensors

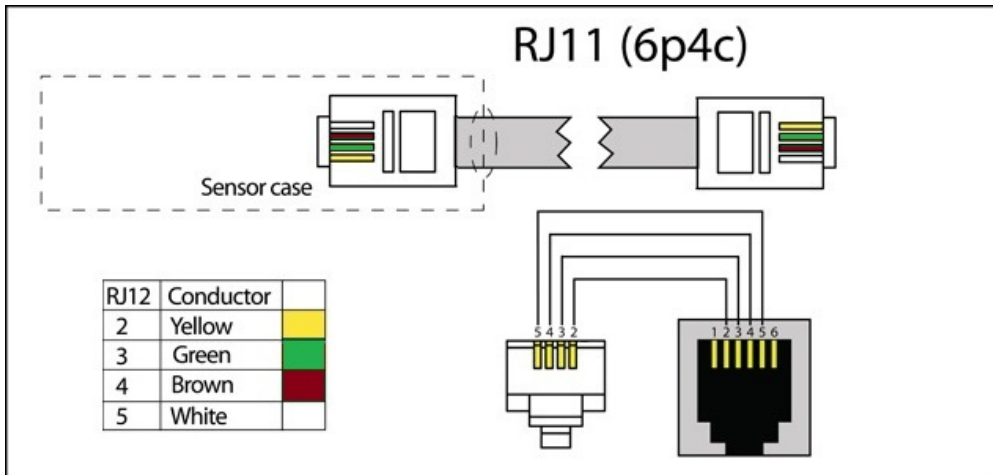

Connecting VT520

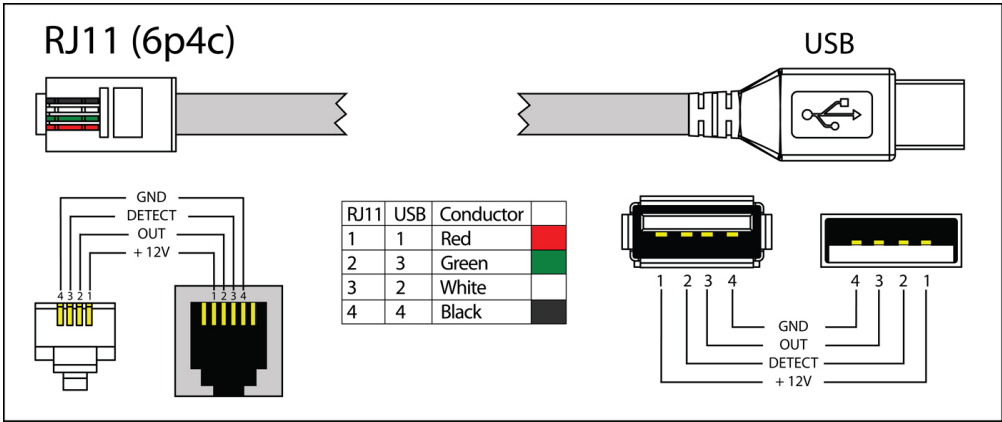

Connecting VT570

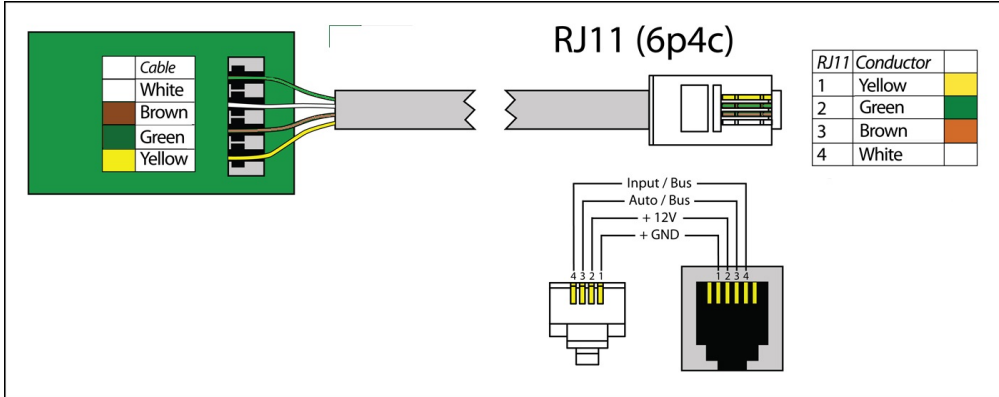

Connecting VT591 Water rope sensor

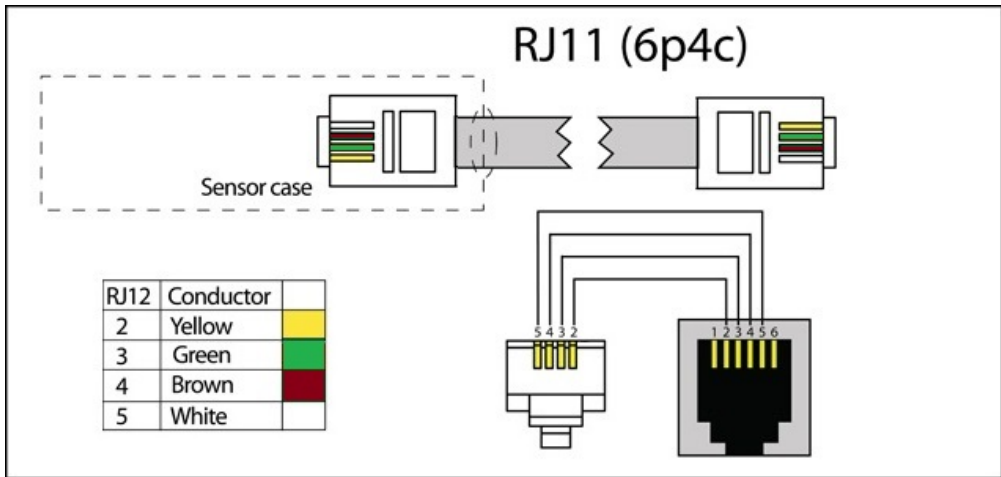

CAN devices connection

CAN sensors and CAN units connection

1. Connect CAN devices to any port CAN1 or CAN2 on the monitoring system using a cable supplied. CAN sensors can also be connected to the port of another CAN sensor or CAN unit which are connected on the CAN bus. Determination of the devices and its connection is done through web-interface.

You can connect up to maximum 8 CAN sensors and CAN devices together on one CAN bus (approximately) !

2. The TR should be "ON" for the last sensor on each bus "CAN 1" and "CAN 2". See section "TR" below.

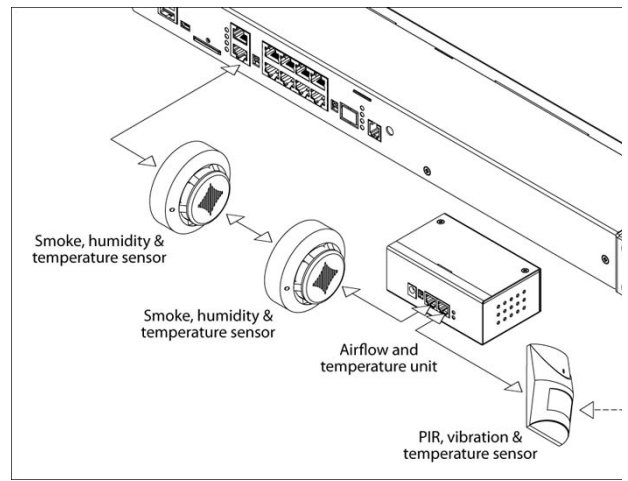
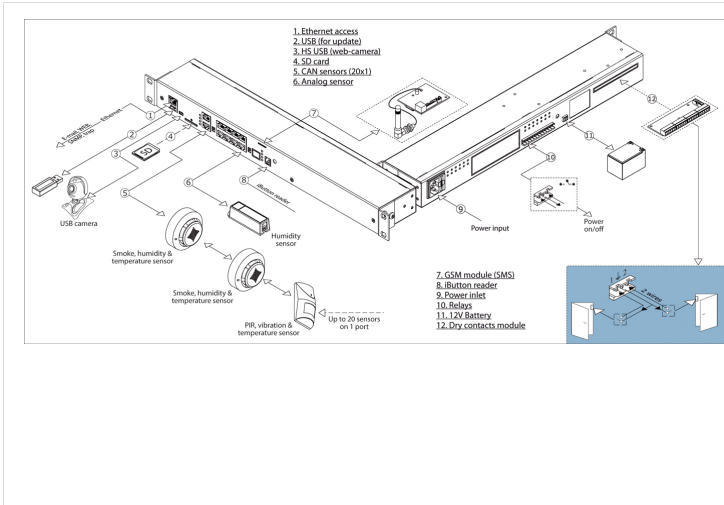

This procedure applies to the following sensors, which are supported by the appliance and are connected to the CAN ports:

CAN sensors:

- VT430 / Rack control unit
- VT440 / Dry contacts unit
- VT460 / Smoke, temperature and humidity sensor
- VT470 / PIR, temperature and vibration sensor
- VT490 / Temperature and humidity sensor

CAN extension unit:

- Analog sensor unit (VT408)

TR termination switch

Old models of master units has TR button, it should be switched ON (terminated).

The last sensor TR switch on a CAN chain must always be terminated, (switched ON). Sensors on a CAN bus that is in the middle should have TR switched OFF.

FR should always be OFF.

TR switch is always the DP switch nearest to CAN bus.

VT430, VT408:

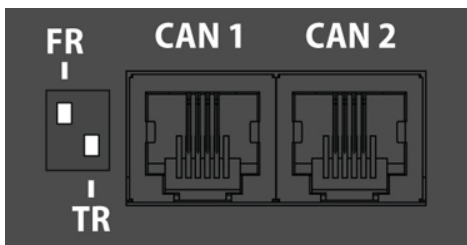

pic.1.1: FR is OFF, TR is ON.

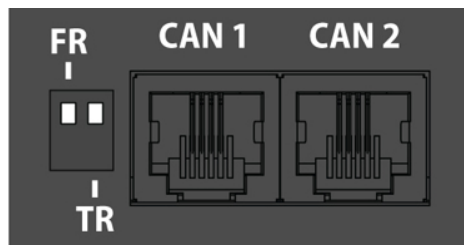

pic.1.2: FR is OFF, TR is OFF.

VT440:

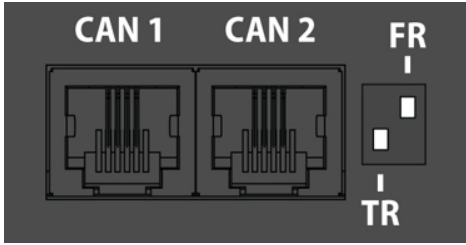

pic.2.1: TR is ON, FR is OFF.

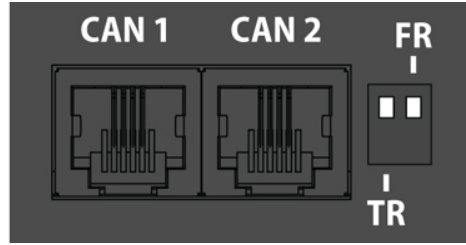

pic.2.2: TR is OFF, FR is OFF.

VT460:

Use supplied 2 pin cover to choose one of the following positions:

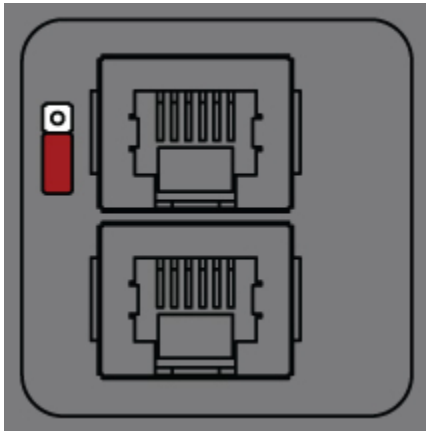

pic. 3.1: TR is OFF.

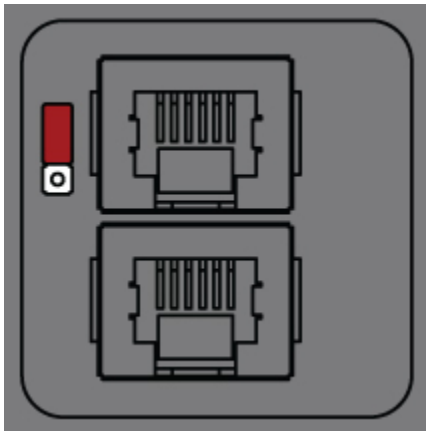

pic. 3.2: TR is ON.

VT470:

Use supplied 2 pin cover to choose one of the following positions:

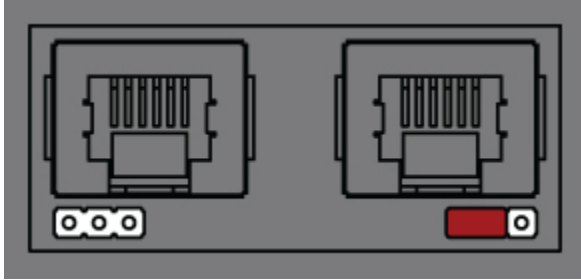

pic. 4.1: TR is OFF.

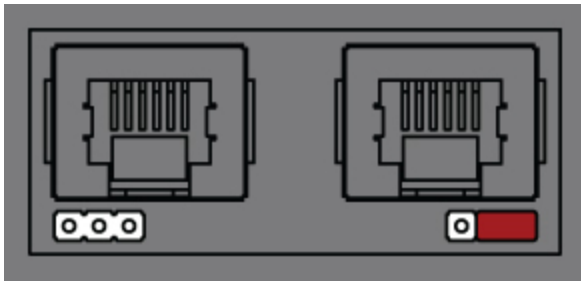

pic. 4.2: TR is ON.

VT490:

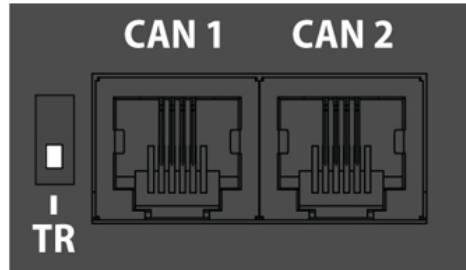
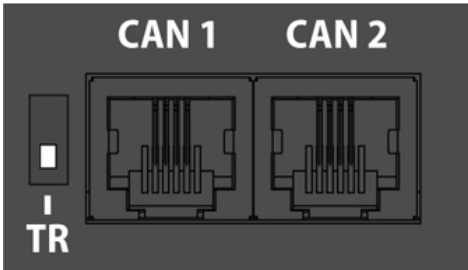

Connecting other CAN sensors and units

Connect CAN sensors and units using any 4 wire or 6 wire cable between each other or to the master unit.

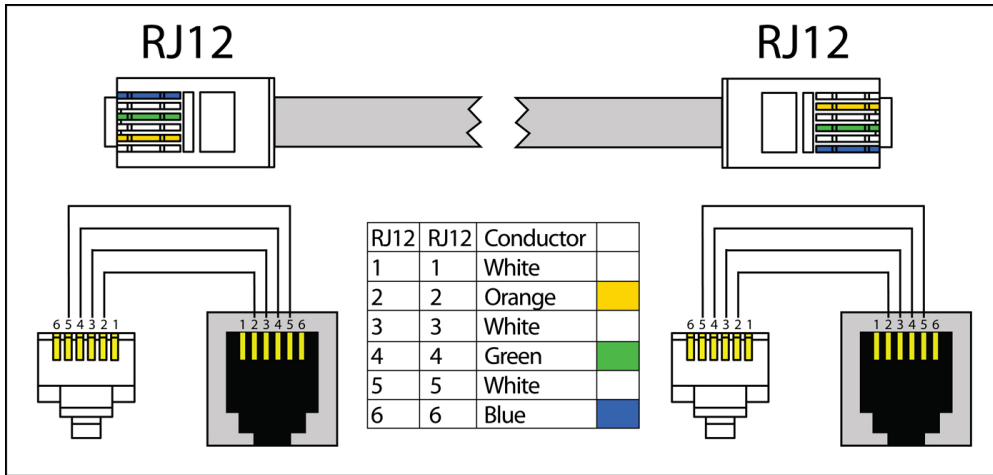

LEDs

CAN sensors have LEDs that indicate the following states:

- Red continuous light, green flickers - no communication with the master module
- Red continuous light, green is off - there is a connection with the master unit, but is not included in the monitoring system (not configured)
- Red is off, Green continuously light - work as part of a monitoring system
- All LEDs are off: no power or sensor is defective.

see also:

AC, DC meters connection

AC. DC metering

Connect AC, DC transceiver with a supplied RJ-11 (6P4C) or RJ-12 (6P6C) cable to any analog port "A1 .. A8" or "Sensor" port. Determination of the sensor type and connection will occur automatically. Connect transceivers to AC, DC meters by any 2/4 wire cable.

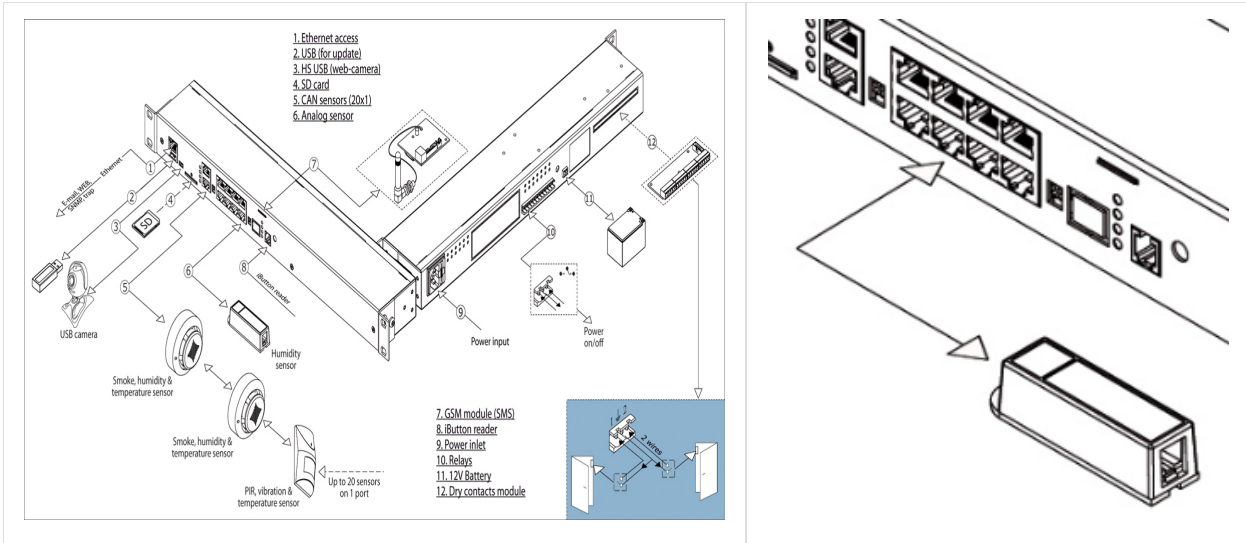

developer notes: change picture (addchange)

This procedure applies to the following AC, DC devices, which are supported by the appliance and are connected to the analog ports:

	AC DC transceivers	Metered Voltage	Isolation	Connected AC, DC meter
1	DC current meter (VT405)	0-60 mV	1 kV	VT100
2	Current converter (VT406)	-4.. +4 V	□	HOS-100V1, HOS-100V11
3	Current transmitter (VT407)	0-5 V	□	HAT-100V1
4	DC monitor (VT410)	0-60 V	1 kV	□
5	Current Loop transceiver (VT420)	4-20 mA	1 kV	4-20mA outputs

For VT405 and VT410 use only 3-pair (6P6C) cable for sensor connection!

Connect transceiver to monitoring unit

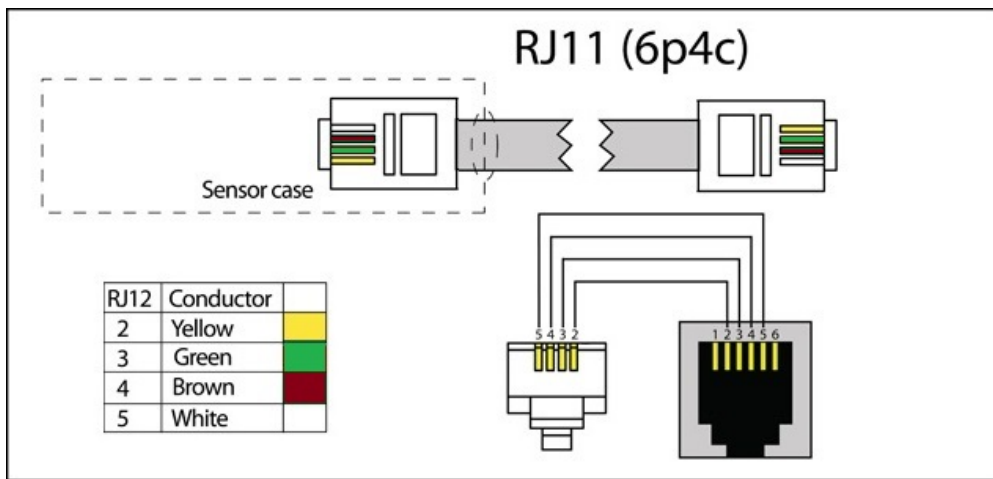

developer notes: change picture (addchange)

Connect transceiver to current shunt

developer notes: add picture (addchange)

Connect transceiver to Hall sensor

developer notes: add picture (addchange)

Measure DC voltage

developer notes: add picture (addchange)

Connect transceiver to 4-20mA outputs

developer notes: add picture (addchange)

Connecting reader

I-Touch button or ITouch Proximity readers can be connected to the port "Reader" using RJ9 (4P4C) connector. The reader is determined automatically. Only VT8101, VT8101T, VT800 and VT8110 have "1-Wire" port.

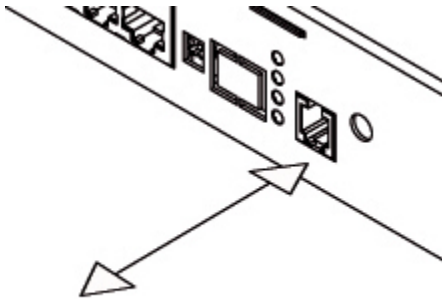

Check the PCB. DIP switch 2 should be in "ON" position.

Connecting I-Touch Button

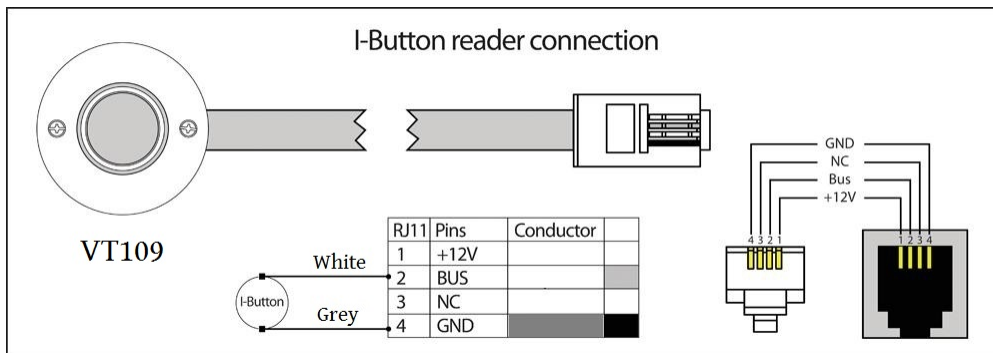

I-BUTTON readers have two wires.

- Ground (GND)
- Data wire (BUS)

Reader's ground wire is connected to the GND pin on RJ9 connector. Data wire of I-BUTTON reader is connected to the BUS contact on RJ9 connector.

Connecting Proximity reader

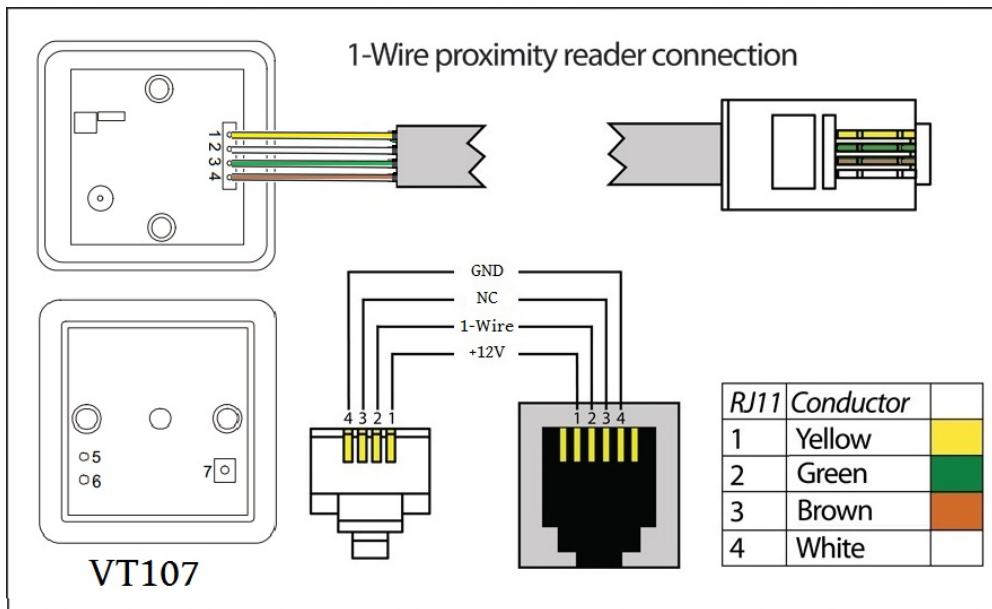

Proximity readers have 3 wires:

- Power (+12V)
- Ground (GND)
- Data wire / 1-Wire (BUS)

Connecting relays

SC8100 and SC8110 have the possibility to connect up to 4 loads managed by built-in relays . In the case of SC8100 built-in relays have independent separate entrances and exits. In case of SC8110 appliance, power is applied to all inputs of 4 built-in relays. The appliance uses latching relays, when power on appliance switches on/off, relays remain in command position!

Connecting the load to SC8100 by relays

To connect an external load, connect the wires from the external power supply to the appropriate medium (2) clamps of the relay terminal plug, the load to the left (1) or right (3) clamps of the plug. Insert the plug into the relay socket terminal RLY1 ... RLY4. By command, relay will switch on or off the load. The maximum possible output current of the relay - 10A.

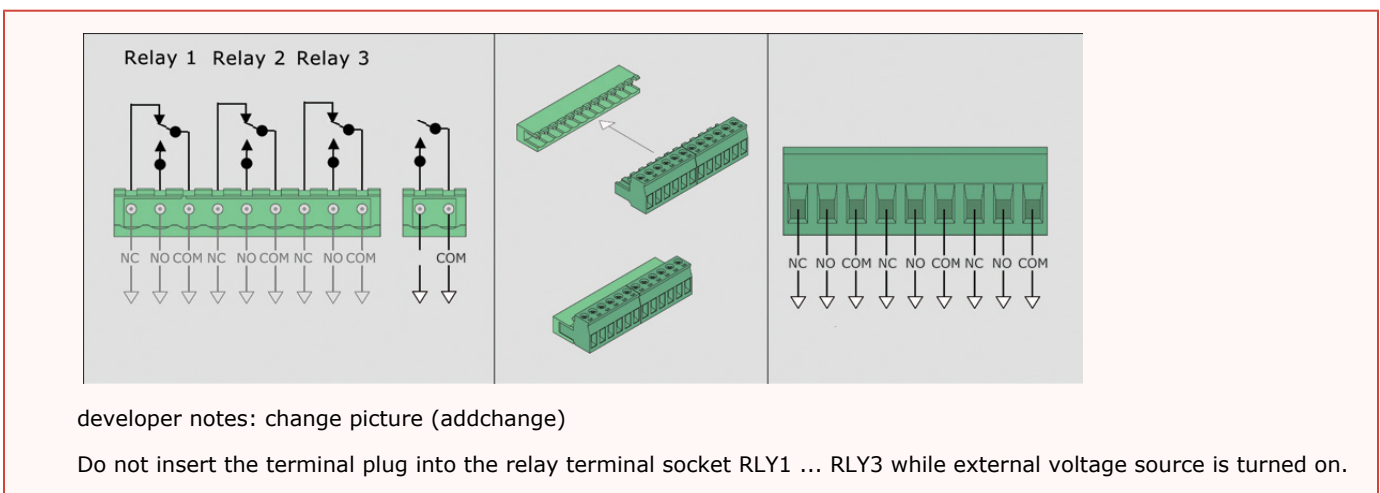

Connecting the load to SC8110 through outlets

To connect an external load, connect power cable from the load to the output "Output 1 .. 4" of the appliance. By command, relay will switch on or off the load.

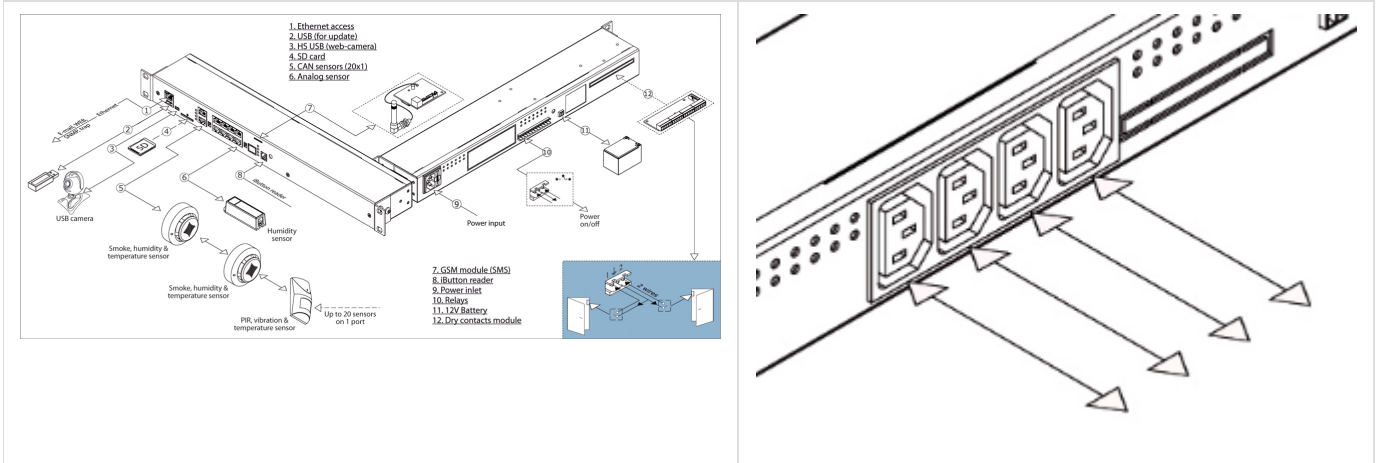

developer notes: change picture (addchange)

Electrical characteristics	Value
The maximum possible total input current on 4 relays	10A
The maximum current load on the relay	10A

To avoid breakage, do not connect the relays loads when the appliance is turned on.

Connecting dry contacts boards

VT16 Dry contacts board mounting

Dry contacts connecting diagram

VT8101, VT8110, VT8101T, VT800 have the possibility to install Dry Contacts board. It is a device mounted and connected inside of master unit. Can be used together with any contacts, for example with door or window contacts, circuit breakers etc.

Allows to control 16 dry contacts.

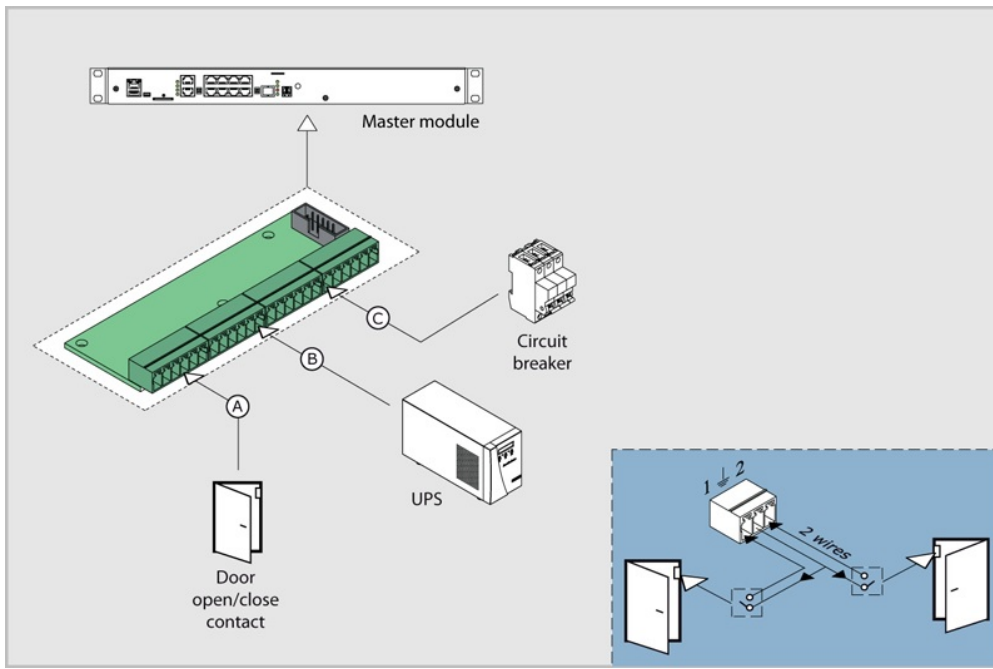

Supplied with Dry contacts

Nº	Components	Description
1		Dry contacts board
2		BH10 cable
3		Screw M3*5mm
4		Relay terminal plugs

Installation of a board

Disconnect device power cable.

- | | | |
|---|--|---|
| 1 | | <p>Carefully unscrew three screws holding the cover and open it.</p> <p>Antenna, GSM or Dry Contacts board can be already installed inside. Carefully open the box by unplugging, if necessary, any cables that are connected from top cover to bottom cover.</p> |
| 2 | | <p>Break 6 steel bridges in the dry contacts hole of the appliance case. Using forceps (cutter) with thin nozzles cut the thin bridges in the hole. Make sure that no burrs are left.</p> |

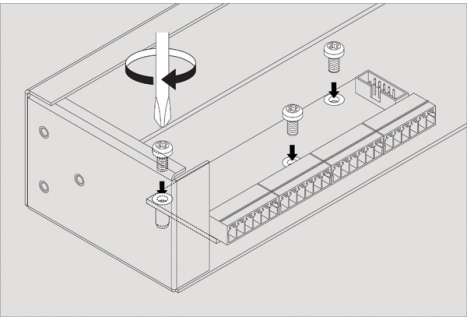
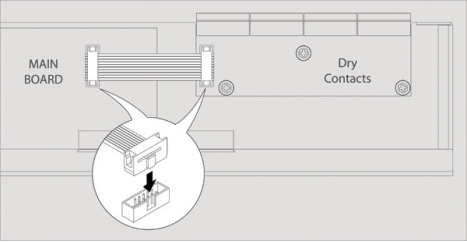
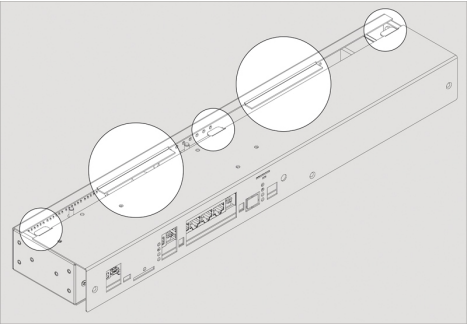
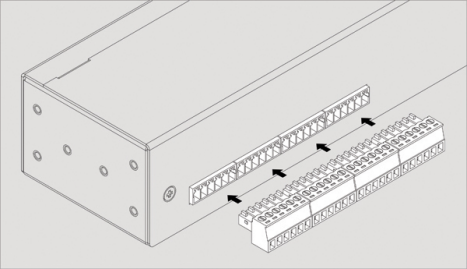
3		<p>Set up dry contacts board on 3 steel spacing sleeves inside the appliance case, attach the board with three M3 screws from supply to the sleeves.</p>
4		<p>Connect "10 wire BH10 flat cable" supplied with "dry contacts" board to the connector on the board card and on the appliance motherboard. Close and fasten the cover.</p>
5		<p>Check if all the cables are connected. Carefully place top cover back so that all cover wings fit in and all cutoff points match the panel holes. Then use 3 screws to close the enclosure. Check whether the burrs prevent dry contact board from being inserted into the hole, remove them if needed.</p>
6		<p>Connect dry contacts to the unit using terminals.</p>

VT32 Dry contacts board mounting

Dry contacts connecting diagram

VT440 has the possibility to install Dry Contacts board. Can be used together with any contacts, for example with door or window contacts, circuit breakers etc.

Allows to control additional 32 dry contacts.

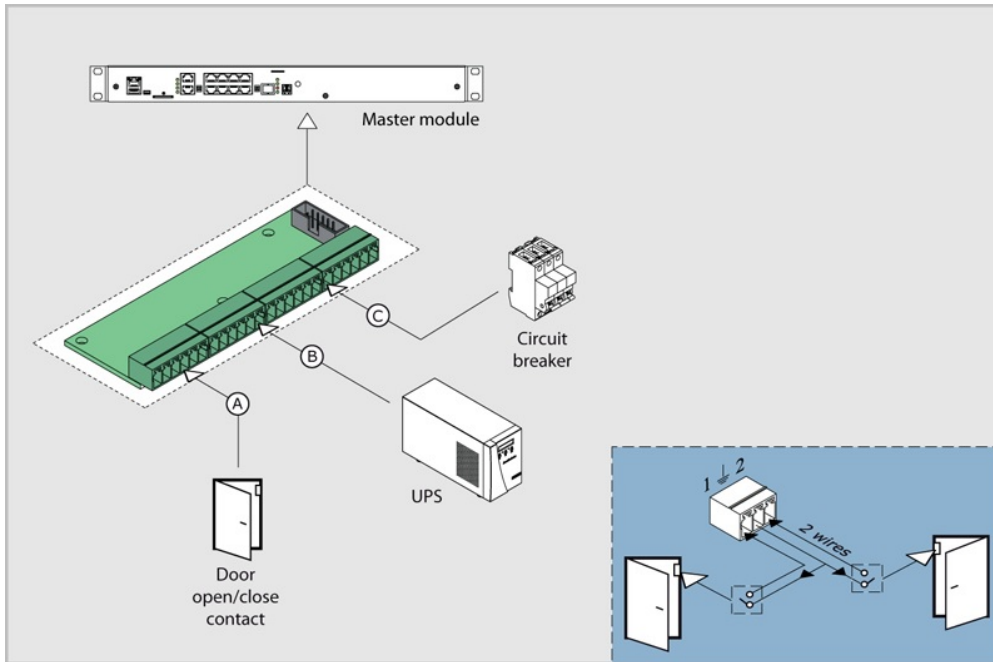

Supplied with Dry contacts

Nº	Components	Description
1		Dry contacts board
2		BH10 cable
3		Screw M3*5mm
4		Relay terminal plugs

Installation of a board

Disconnect device CAN cable.

1	Carefully unscrew three screws holding the cover and open it.
2	Break 6 steel bridges in the dry contacts hole of the appliance case. Using forceps (cutter) with thin nozzles cut the thin bridges in the hole. Make sure that no burrs are left.
3	Set up dry contacts board on 3 steel spacing sleeves inside the appliance case, attach the board with three M3 screws from supply to the sleeves.

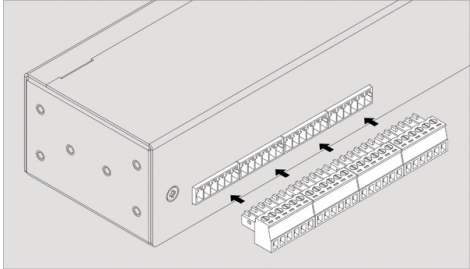
4		Connect "10 wire BH10 flat cable" supplied with "dry contacts" board to the connector on the board card and on the appliance motherboard. Close and fasten the cover.
5		Check if all the cables are connected. Carefully place top cover back so that all cover wings fit in and all cutoff points match the panel holes. Then use 3 screws to close the enclosure. Check whether the burrs prevent dry contact board from being inserted into the hole, remove them if needed.
6		Connect dry contacts to the unit using terminals.

Connecting GSM modem

Connection diagram

All monitoring units, VT8101, VT8101T, VT8110, VT800, VT808 and VT1908 have the possibility to install GSM modem. The device is mounted and connected inside of master unit. Needed when network is absent or for reservation of a connection channel of master unit with Internet; for sending SMS notifications and SMS commands.

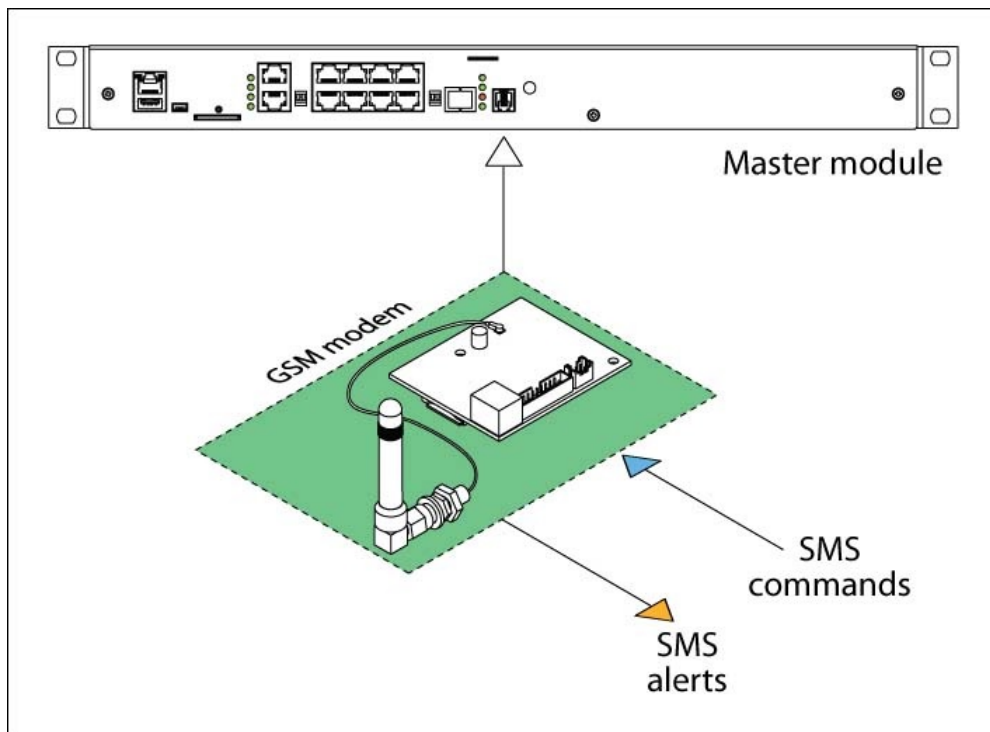

Supply includes

Nº	Component	Description
1		Modem board

2	 Unknown Attachment	Antenna
3		Antenna wire
4		BH16 cable
5		M3*5mm bolts. 3pcs

Installation of GSM modem

To install and to connect extension units: switch off appliance, unplug from the outlet or disconnect the power connector.

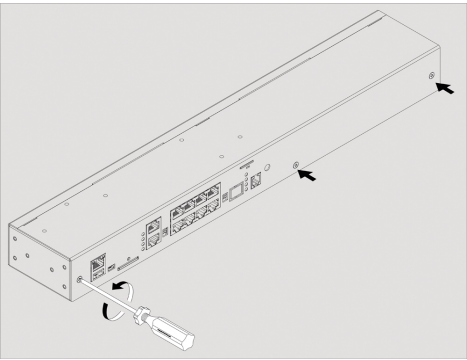
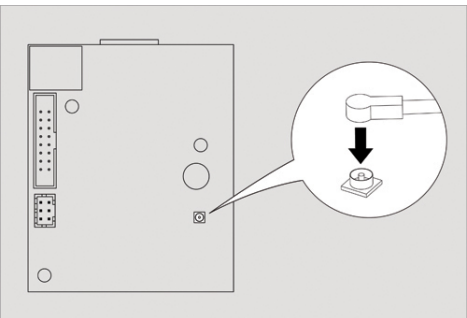
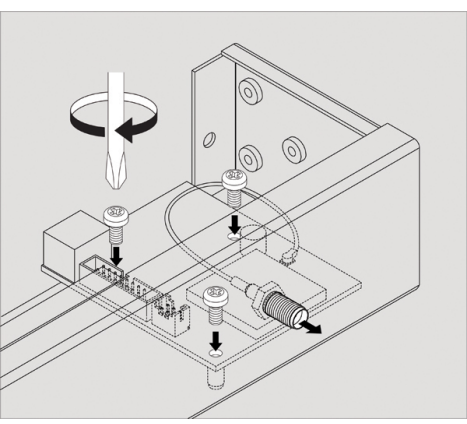
1		<p>Carefully unscrew three screws holding the cover and open it.</p> <div style="border: 1px solid black; padding: 5px; margin-top: 10px;"> <p>Antenna, GSM or Dry Contacts module are installed inside. Carefully open the box by unplugging, if necessary, any cables that connect from top cover to bottom cover.</p> </div>
2		<p>Connect antenna cable to the modem board. Carefully connect the U-FI antenna cable to the input U-FI connector and gently press it. If possible install the connector on the seat with a magnifying glass!</p>
3		<p>Set up the GSM modem card on 3 steel spacing sleeves on the cover, attach card to the sleeves using three M3 screws supplied with the modem.</p>

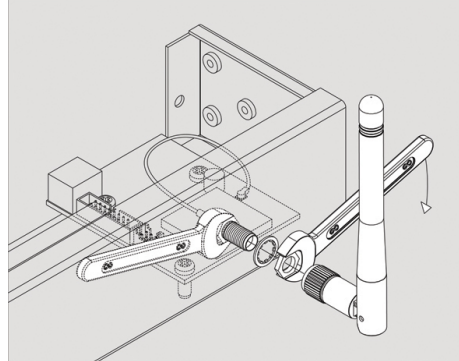
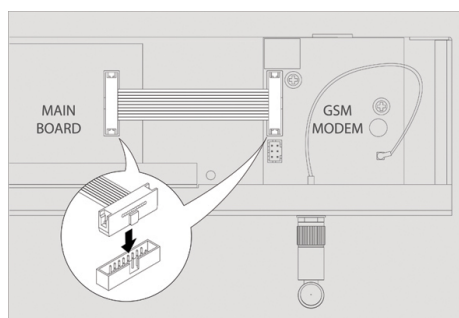
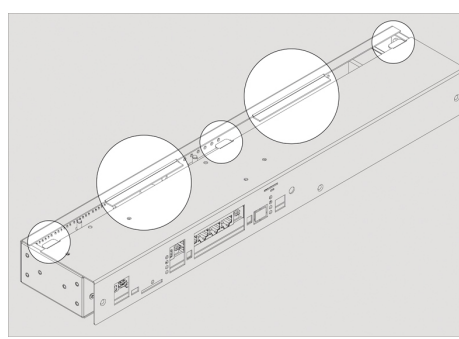
4		<p>Set the SMA connector antenna cable to the rear or to the front panel of the appliance into the corresponding SMA hole. Put on the SMA connector gold-plated washer and nut from the supply, holding SMA connector with one key, securely tighten the nut with the other key.</p> <div style="border: 1px solid black; padding: 5px; margin-top: 10px;"> <p>Do not tighten SMA connector with one key, you can break the cable and the connection would be lost!</p> </div>
5		<p>Connect 16-pin flat cable to the connectors on the modem card and on the appliance motherboard. Close and fasten the cover. If necessary, install the SIM card into the appropriate hole.</p>
6		<p>Carefully place top cover back so that all cover wings fit in and all cutoffpoints match the panel holes. Then use 3 screws to close the enclosure. When installing the green dry contact connectors can go tight, check the burrs and remove them with rasp!</p>

Connecting backup battery

Backup battery can be connected to the following systems: VT8101, VT8110, VT8101T, VT1808, VT1908.

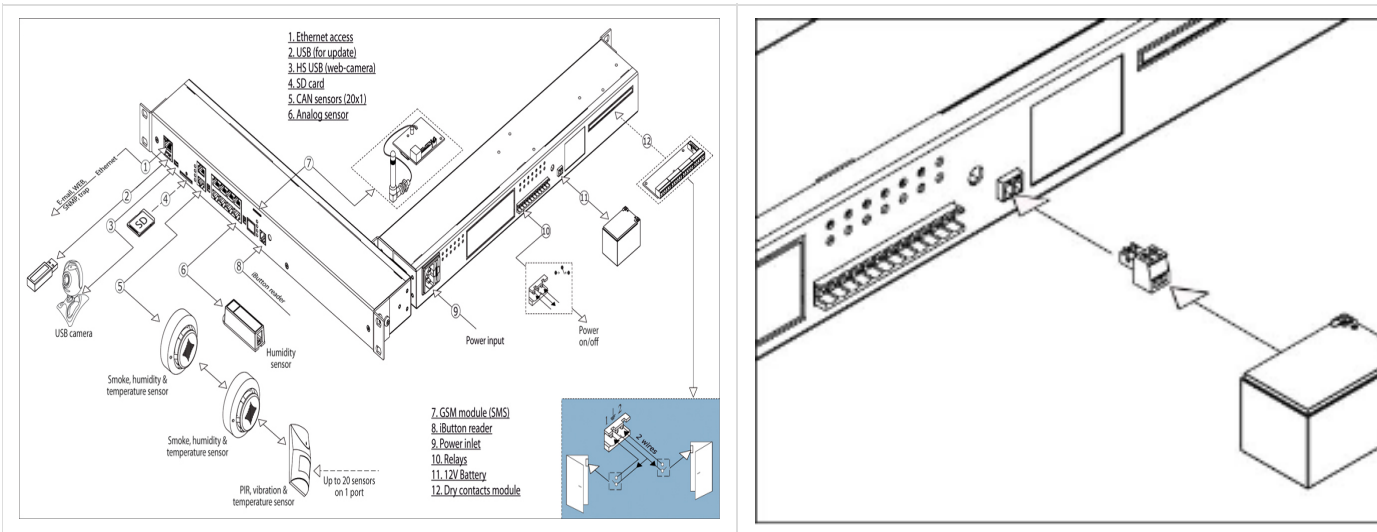

If necessary, connector "DC 12V" can be connected to the backup battery 10-12 V with supplied plug 3.5 mm. Battery discharge starts as the battery voltage exceeds over the appliance internal voltage 12V.

The input voltage of backup power must not exceed 11,6V! The battery can be charged only if the input voltage does not exceed 12,6V!

Connecting USB camera

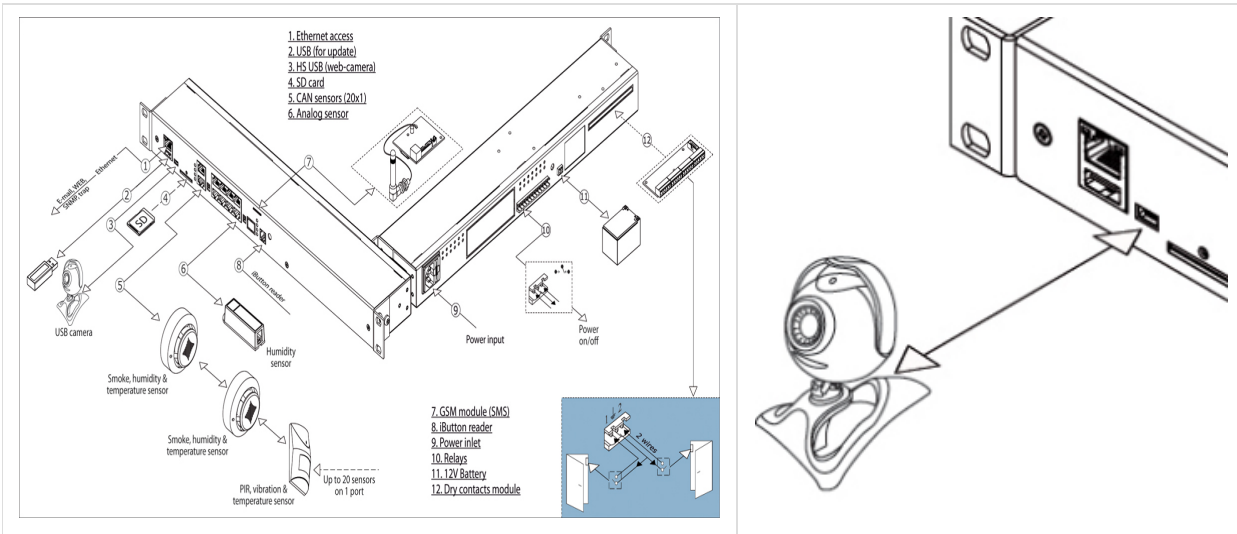

If necessary, by means of supplied cable USB-A / MiniUSB AB, you can connect any USB camera of class Linux UVC Webcam which supports MPEG. USB camera is connected to "HS" port. Determination of camera and connection will occur automatically. USB camera can also be connected to USB A port, however, it will have a lower resolution. Do not use any USB extension cables when connecting the camera to USB A port, use only the cable supplied with the camera.

List of USB cameras

We recommend the next Linux UVC cams:

It is possible to connect the following web-cameras to USB and HS ports:

Manufacturer	Model
Logitech	C210

It is possible to connect the following web-cameras to HS port only:

Manufacturer	Model	
Logitech	C270	
Logitech	C310	
Logitech	C510	
Genius	FaceCam 1000X	Dark picture
Genius	FaceCam1020	Dark picture

Initial Configuration

This section includes the following:

- [Connecting the device](#)
- [Interface overview](#)
 - [Interface overview \(v2.0.1 - v2.2.5\)](#)
- [User access and permissions](#)
 - [User access and permissions \(v2.0.1 - v2.2.5\)](#)

Connecting the device

System configuration and monitoring is done through web-interface. To access the web-interface you need to enter an IP address or a name in a command line of your browser to which your system is bound to.

Please use any of Firefox, Chrome, Safari as web-browser. Interface has HTML5 platform that is not fully supported by IE.

Default network settings

The factory network settings of the device:

1	DHCP client	switched off
2	Hostname	Vutlan
3	IP-address of device	192.168.0.193
4	Network mask	255.255.255.0
5	Broadcast	192.168.0.1
6	Gateway	192.168.0.255
7	Primary DNS	192.168.0.1

To start working with the appliance your PC must be in the same network as the new appliance! To do this please set up on your PC: subnet mask: 255.255.255.0 and IP-address: 192.168.0.XXX, where XXX = number from 0 to 192, from 194 to 254



To configure network settings on your PC, follow these steps: Start >> Control panel >> Network Connections >> Right-click on your LAN (Local Area Connection) >> Properties >> double click on Internet Protocol (Internet Protocol (TCP / IP))

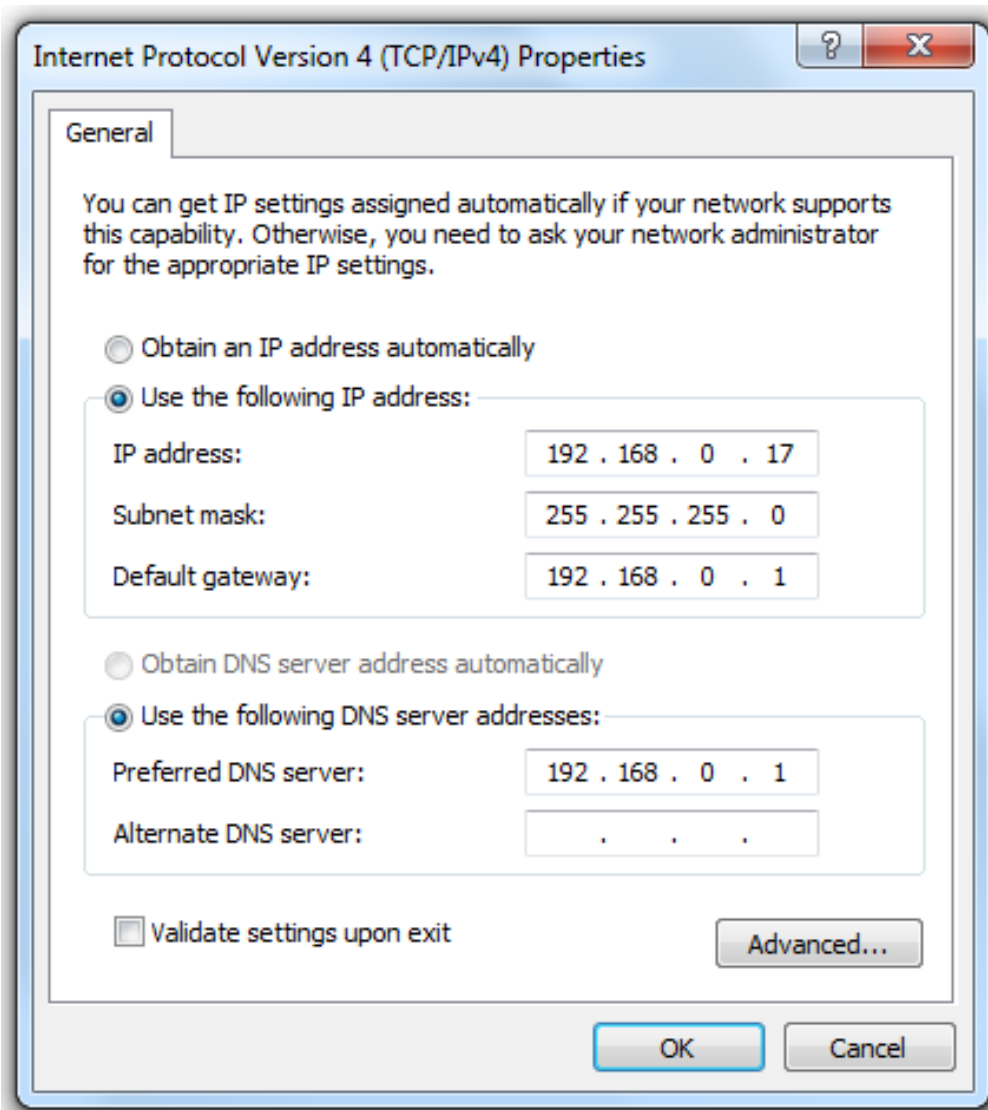



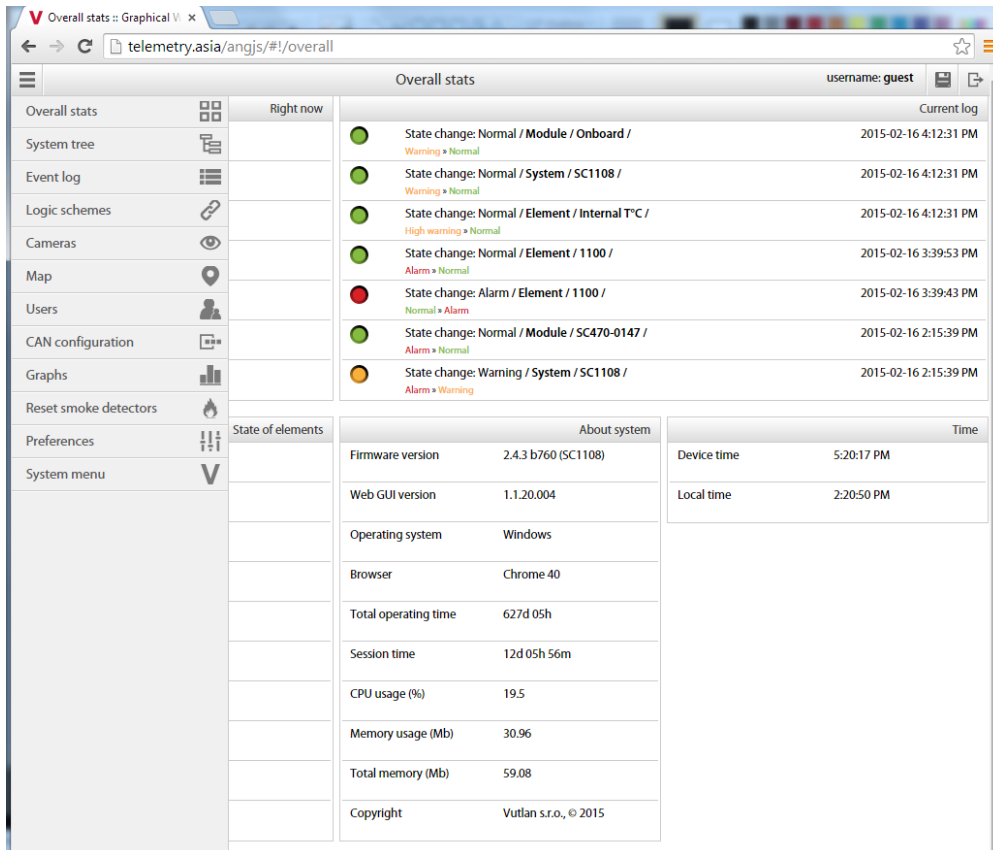

Interface overview

Control of the device is made through web-interface. The general view of the interface is shown below:



1. "Toolbar", includes:

-  - Menu button
-  - Save settings to flash
-  - Exit

2. "Menu" panel is opened by pressing  button. It includes:

- Overall stats - shows general statistics;
- Group tree - shows all sensors and devices in a folder tree (the tree is set up by the administrator manually);
- System tree - shows all sensors and devices in a system tree (the tree is set up automatically by the system according to sensor groups);
- Event log - shows system log;
- Logic schemes - to set automatic actions on events happening in the system;
- Cameras - shows all cameras connected to the system;
- Map - designed for visual placement of elements on the plan/map;
- Users - to manage user accounts and permissions;
- CAN configuration - to control CAN devices;
- Graphs - for comparative analysis of the history of sensor readings;
- Power management - load management panel. Only available for SC8110, SC1108 and SC3208;
- Access control - to manage access keys; (this menu is available only for ???);
- Preferences



- Web GUI - interface language, data reload interval, enable sound for alerts;
- Network - network settings;
- Time - time zone, NTP server for time synchronization, current device date and time;
- Syslog - syslog server settings;
- DynDNS - DynDNS service settings;
- SNMP - SNMP settings;
- SD card - options;

- System menu
 - About - Firmware version, Web GUI version, operating system, browser, reboot the system;
 - Firmware - update control panel;
 - Export - export sensor data, export log and export settings;

3. Overview panel - shows general statistics

- Right now - shows number of elements in the following states at the moment: very low, low, normal, warning, alarm;
- State of elements
- Current log - shows 5 last last syslog events;
- About system
- [Interface overview \(v2.0.1 - v2.2.5\)](#)

User access and permissions

By default, the device has "guest" account with the most extensive access rights (all rights for view/write):

username: guest

login: guest



To change the user go: "Main menu" >> "Users".

Administrator account, username and password

To improve security it is needed to create a new user account with the highest access rights (all rights for view/write), and to reduce the access rights of the "guest" account or completely remove it from the user accounts.

Users		
List of users		
	user	read: all write: all
	atel	read: all write: all
	wuuser	read: all write: all
	guest	read: all write: all
	user	read: 2 write: 2

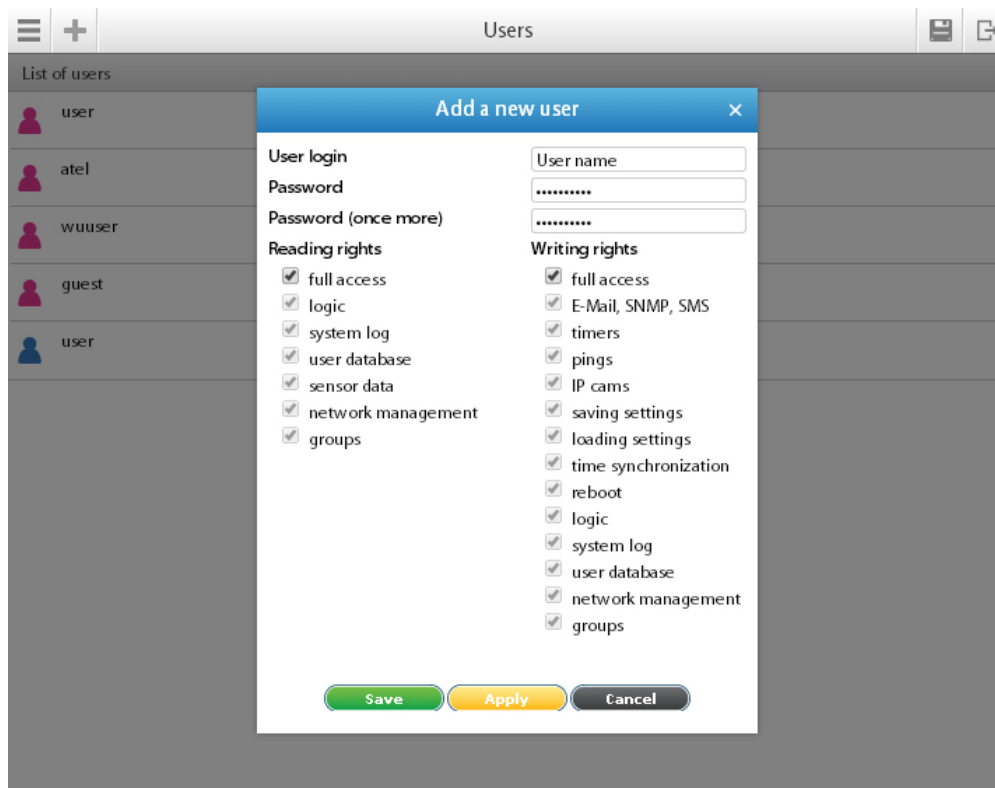

To manage the user accounts go to "Main menu" >> "Users".

To create a new user account press "add" button: 

To edit an existing user account, select it from the list of accounts, a modal window with options will pop up.

Select user rights in the window that appears and after that click "Save".

To delete an existing user account, select it from the list of accounts and click "Delete".

User access

In order to limit user access to the subsystems of the device the following groups of access permission are used:

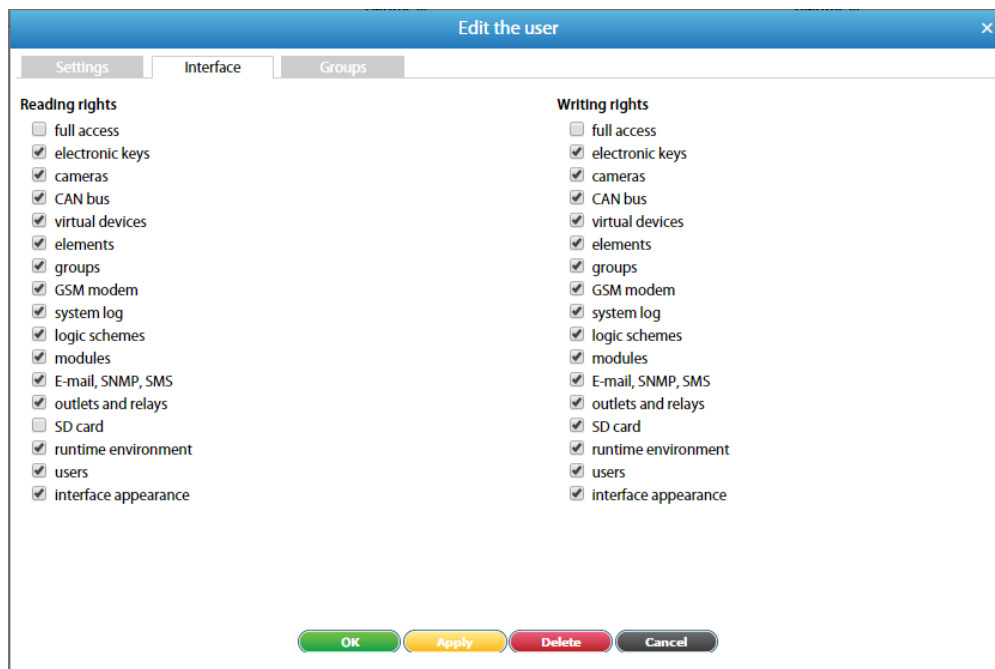

To prevent the user from seeing other user accounts, it is necessary to uncheck the box ("Users")!

Settings recovery

The appliance has the ability to save settings to a backup file and restore it later. To save a file with the system settings, follow these steps: in the appliance interface go to "Main menu" >> "System menu" >> "Export" >> "Download current settings". The file will be saved using name "settings.vut".

To restore, to change or to clone settings, copy the file "settings.vut" to the root of a USB-flash drive, without changing the file name. Plug the USB flash drive into the appliance socket "USB" and wait. The update process is displayed on the front panel with flashing LED "ERR". If successful, the "ERR" LED will go off, and "ACT" LED will blink for a while with increased frequency. If unsuccessful "ERR" LED will remain lit. Remove USB-flash drive and reboot the system. Test the appliance.

Password recovery

Sometimes, in case of loss of all the data on the appliance or if you have equipment with unknown settings, it is may be necessary to restore the password identifier and change it to a "guest". Use the file "[resetusers.vut](#)", copy this file to the root of a USB-flash drive, without changing the file name. Plug the USB flash drive into the appliance socket "USB" and wait. The update process is displayed on the front panel with flashing LED "ERR". If successful, the "ERR" LED will go off, and "ACT" LED will blink for a while with increased frequency. If unsuccessful "ERR" LED will remain lit. Remove USB-flash drive and reboot the system. Test the appliance.

User access and permissions (v2.0.1 - v2.2.5)

developer notes: linkchange

Quick Configuration

Turn on the appliance, set up the network settings, proceed to configure other settings and actions.

- [Network settings](#)
- [Setting up time](#)
- [Creating floor map plan](#)
- [Sensor configuration](#)
- [AC, DC meters configuration](#)
- [Creating groups of elements](#)
- [Creating notifications](#)
- [Creating ping](#)
- [Creating timer](#)

- Creating Get SNMP element
- Add IP cam
- Adding logic schemes
- Access control
- Setting up GSM modem
- Setting up CAN
- Setting up dynamic DNS
- Logs export setting
- Relay switching
- Saving system logs to SD card
- Dry contacts settings

Network settings

Default network settings can be found here: [Connecting the device](#).

The screenshot shows the 'Preferences' web interface with the 'Network' tab selected. The interface includes a top navigation bar with 'Web GUI', 'DynDNS', 'Network', 'SNMP', 'Time', 'RADIUS', 'Syslog', and 'SD Card' tabs. The 'Network' tab is active, showing the following settings:

- MAC address:** 00:23:98:00:06:D9
- Hostname:** skycontrol
- IP address:** 192.168.1.192
- Network mask:** 255.255.255.0
- Broadcast:** 192.168.1.255
- Gateway:** 192.168.1.200
- Primary DNS:** 192.168.1.200
- Second DNS:** 192.168.1.201
- Third DNS:** 192.168.1.202
- HTTP port:** 80
- Enable SSL:**
- Enable DHCP:**
- Enable CAN:**

To configure network settings go to "Main menu" >> "Preferences">>"Network". Change the settings to the needed values and click "Save".

Available network device settings:

1	MAC address	MAC address of your device, can not be changed
2	Hostname	Host name of the device
3	IP Address	IP-address of the device
4	Network mask	Netmask

5	Broadcast	Broadcast address
6	Gateway	Default gateway
7	Primary DNS	Primary DNS
8	Second DNS	Secondary DNS
9	Third DNS	Third DNS
10	HTTP port	HTTP port
11	Enable SSL	enable or disable SSL
12	Enable DHCP	enable or disable DHCP connection
13	Enable CAN	Enable or disable CAN, needed for CAN sensors and modules

If the default gateway is not known, use IP-address of the computer in the network of the device, which is usually included. The device uses the default gateway to test the network with low traffic.

Determination of IP-address

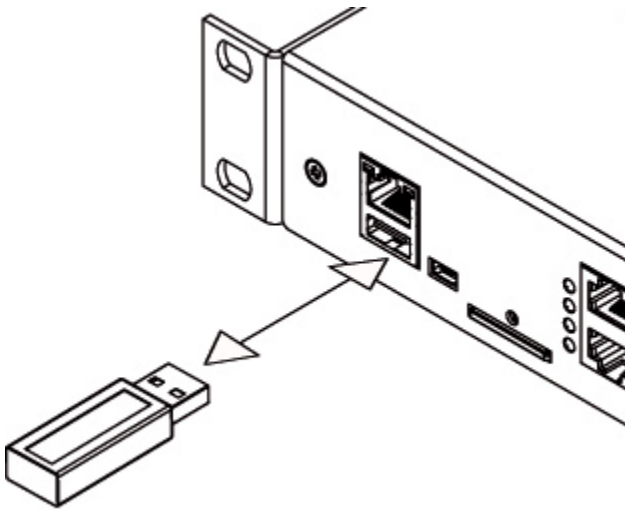

To determine the IP-address of the device insert USB-flash into the device as shown on the picture above, the device will automatically create "dumplog_date_time.txt" file with the current settings (including IP-address) in the root of the USB-flash. After the LED on the USB-flash will stop blinking, remove the drive from the device. Connect the USB-flash to your PC. Open the "dumplog_date_time.txt" file using a text editor.

- [Network settings \(v2.0.1 - v2.2.5\)](#)

Setting up time

☰
Preferences
📄
🔗

Web GUI
Network
Time
Syslog
DynDNS
SNMP
SD Card

Device timezone ▼

NTP server for time synchronization

Automatically synchronize time ▼

Current device date and time

 . . : :

Save
NTP Sync

Time synchronization

To configure NTP for time synchronization, open "Main menu" >> "Preferences" >> "Time" >> "NTP server for time synchronization". For example: 1.europe.pool.ntp.org

Specify the server NTP, synchronization period, and device time zone and click "Save".

The time zone set has to be the same as the time zone of your browser (Operating system).

"Current device date and time" corresponds with the time set on the system.

- [Settings up time \(v2.0.1 - v2.2.5\)](#)

Creating floor map plan

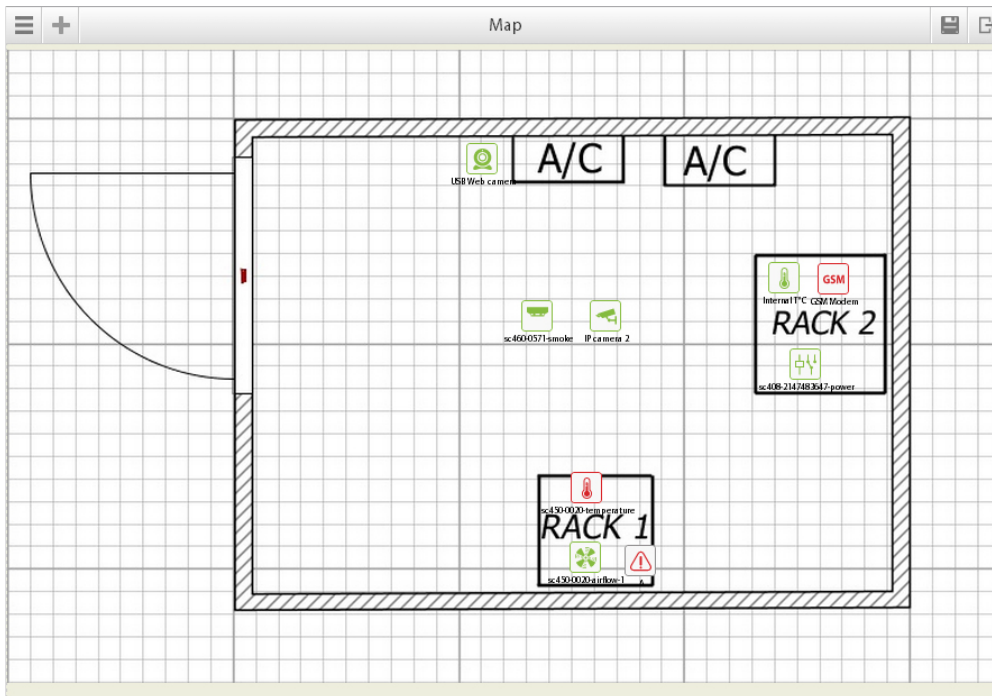

To upload a map or plan , go to "Main menu" >> "Map", click on settings icon "  " >> "New map" >> "Choose File" >> press "OK".

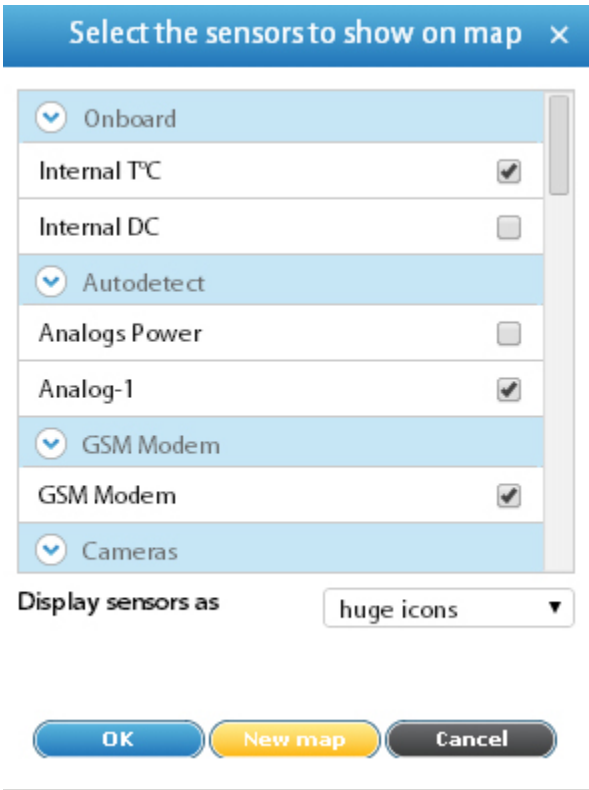

To add/remove elements to the map/plan, press "  " >> select the elements you need to be displayed on the map >> press "OK". Move elements to to the desired location.

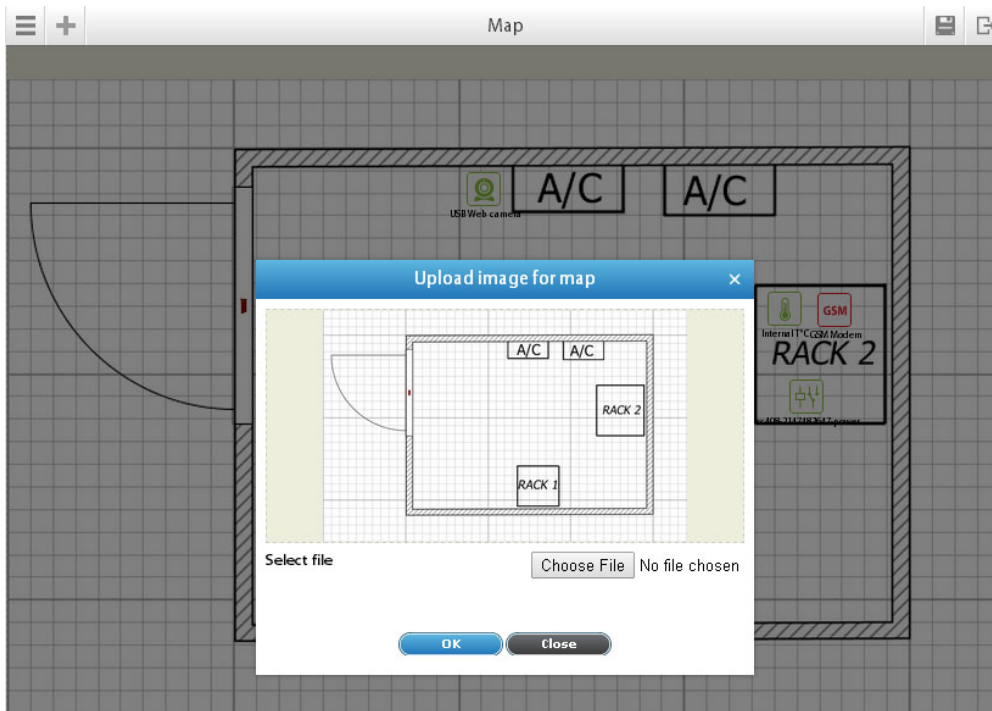

- [Creating floor map \(v2.0.1 - v2.2.5\)](#)

Sensor configuration

To configure a sensor, go to "Main menu" >> "System tree" and click on the sensor element in the tree. A modal window with sensor properties will pop up. Change the needed settings and click "Save" or "Apply" at the bottom of the "Properties" window.

Temperature
✕

Settings

Charts

All data

Name

Internal T°C

ID

1001

Type

temperature

Class

analog

Current state

Normal

Current value

43.5

▼

Low alarm level

35.2

Low warning level

38.8

High warning level

46.0

High alarm level

50.2

K from (k*x + b)

1.000

B from (k*x + b)

0.0

Save

Apply

Cancel

To save sensor properties in the device flash memory press "  " then "OK" to confirm.

All sensors include:

1	Name	Name is given by the system automatically. You can change it to anything you want.
2	Group	Groups are manually created by the administrator in "Group tree" menu.
3	ID	System ID of the element
4	Type	Example: temperature, humidity, vibration
5	Class	Examples: analog, CAN, switch, discrete

All sensors have threshold controls:



On the picture above, "Current value" equals 25.7 and is represented by the small triangle. Currently the triangle is red because it is situated in an "alarm" range above "alarm threshold", which equals 15.0. Hence the sensor says that "Current state" is "Alarm". This value is used by the system "Logic schemes" menu to notify the administrator or take action.

All monitoring systems have built-in sensors value hysteresis!

- [Sensor configuration \(v2.0.1 - v2.2.5\)](#)

AC, DC meters configuration

To configure a current or voltage meter, go to "Main menu" >> "System tree" and click on the current or voltage sensor element in the tree. A modal window with sensor properties will pop up. Change the needed settings and click "Save" or "Apply" at the bottom of the "Properties" window.

Voltage converter
✕

Settings

Charts

All data

Name

ID 204001

Type fvoltage

Class analog

Hardware port 1

Current state High alarm

Current value 7.77

Low alarm level

Low warning level

High warning level

High alarm level

Expression

OK
Apply
Cancel

On the picture of the voltage converter is used the coefficient = 2, this means that the sensor is used on 10 volts. The sensor on the 60V has K = 12, the current sensor on the 100A has a value of K = 20 and so on.

To save properties in the device flash memory press "  " then "OK" to confirm.

All meters include:

1	Name	Name is given by teh system automatically. You can change it to anything you want.
2	Group	Groups are manually created by the administrator in "Group tree" menu.
3	ID	System ID of the element
4	Type	4-20mA sensor or 0-5V voltage sensor
5	Class	analog

All meters have threshold controls:

On the picture above there is a current transducer, coefficient is not still written. If necessary, the formula needs to enter the conversion (Example: $x / 2 - b$, or $\sqrt{x} + b$) value and to designate the name of the connected sensor (Liters, speed or something else depending on the sensor installed.)

All monitoring systems have built-in sensors value hysteresis!

Creating groups of elements

Groups of elements are made for the structural organization of the elements in the system.

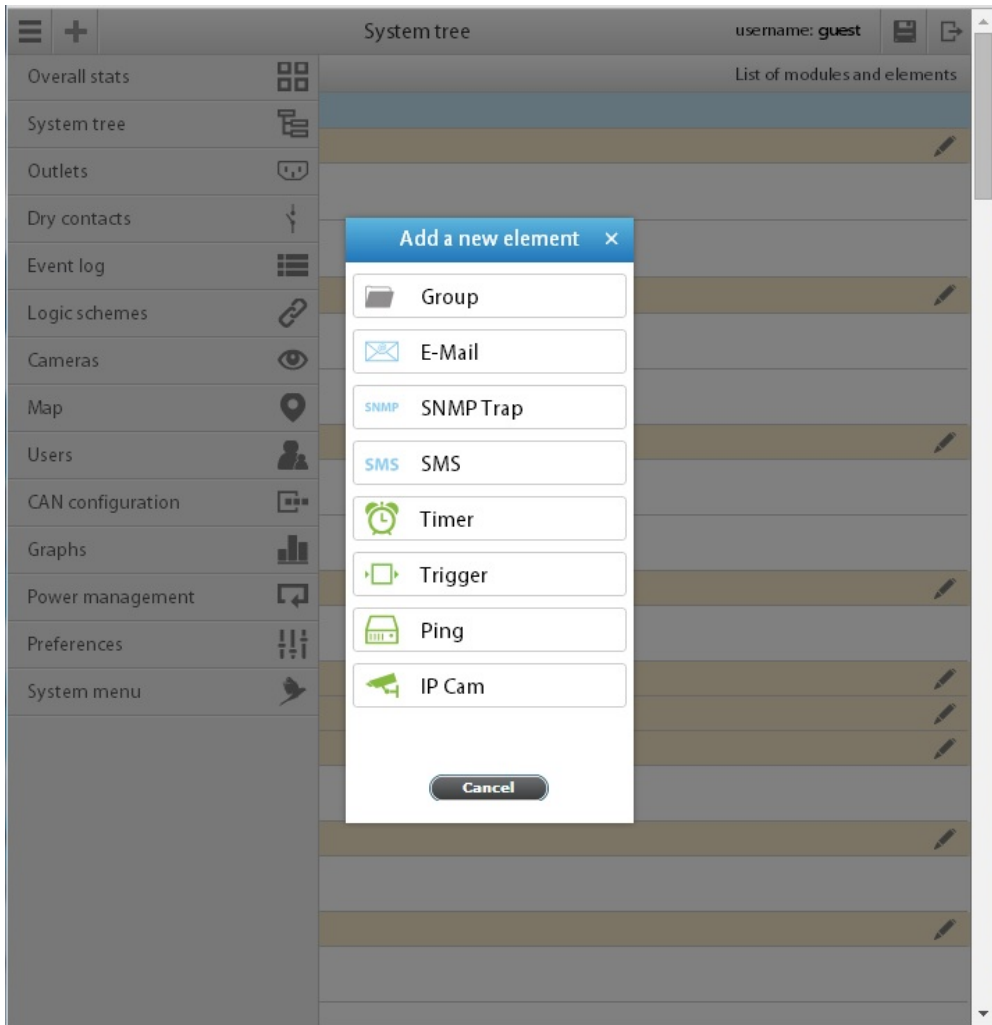

To create a group, push button " + " inside "System tree" menu. Then choose "Group". A modal window will appear. In the dialog box, specify a group name, fill in the description and press "Save".

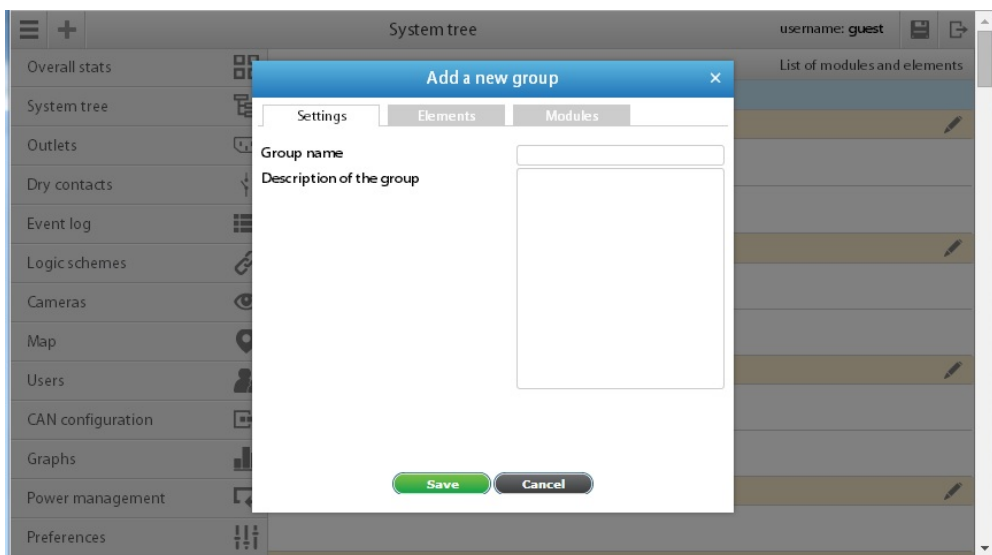

- Creating groups of elements (v2.0.1 - v2.2.5)

Creating notifications

Notifications are intended to inform the user about events occurring in the monitoring system.

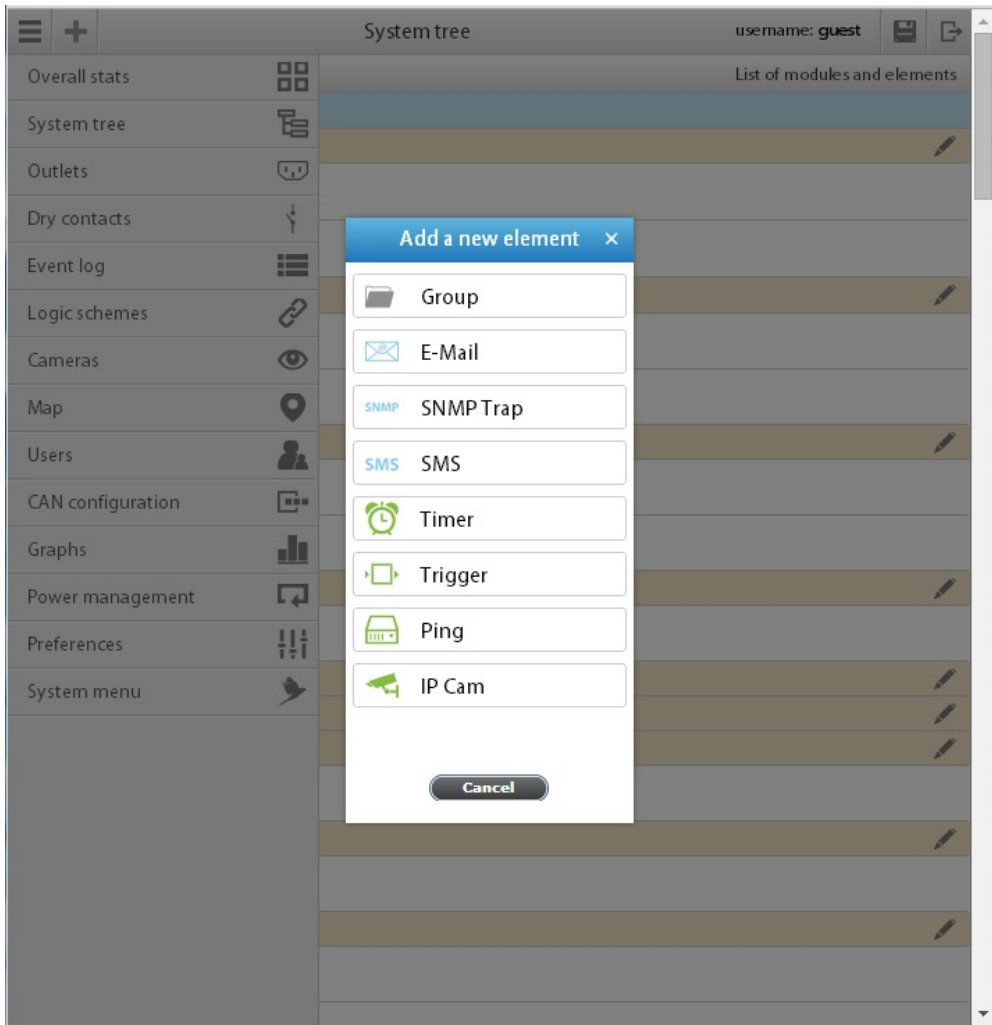

To create a notification, push button " + " inside "System tree" menu. Then choose element to add. A modal window will appear.

It is possible to add the following:

- notification via E-mail;
- notification via SNMP trap;
- notification via SMS;

Notification via E-mail

To create notification via e-mail you have to specify the following parameters:

Parameter	Description
Name	The name of the element in the system
Group	You can specify to which group the notification will be added in "Group tree" menu
SMTP server	Name or SMTP server IP address (smtp.gmail.com)
SMTP port	SMTP server on the correct port number. (e.g. 25 or 465)
Enable SSL	Enable or disable
Login, Password	SMTP server username and password

Mail from	Sender's e-mail address (sky25test@gmail.com)
Mail to	Recipient's e-mail address (sky25test@gmail.com)
Message	Text of the message

E-Mail
×

Name	<input type="text"/>
Group	— no group — ▼
ID	
Type	
Class	
SMTP server	<input type="text"/>
SMTP port	<input type="text"/>
Enable SSL	<input type="checkbox"/>
Login	<input type="text"/>
Password	<input type="text"/>
Mail from	<input type="text"/>
Mail to	<input type="text"/>
Message text	<div style="border: 1px solid #ccc; min-height: 100px; padding: 5px;"> <p>%1 - logic definition %2 - state of sensors %3 - date and time %4 - logic name %5 - sensor name %6 - sensor state %7 - sensor value \n - new line</p> </div>

Save
Apply
Test
Cancel

Contact your mail administrator for assistance with configuring SMTP parameters or the help section of your e-mail provider.

SNMP Traps notification

To create notification via e-mail you have to specify the following parameters:

Parameter	Description
Name	The name of the element in the system
Group	You can specify to which group the notification will be added in "Group tree" menu
SNMP server	Name or SNMP server IP address (192.168.1.10)
SNMP port	SNMP port (usually 162).
Version	Version (v1, v2c or v3)
Community	Community name (public)
USM user	User name for protocol v3

Security level	Security level for protocol v3, mobile version. "noauth" - no authorization, only user name needed; "auth" - with authorization, need to fill in "Auth algorithm" and "Auth password"; "priv" - with authorization and data encryption, need to fill in "Auth algorithm", "Auth password", "Private algorithm" and "Private password";
Auth algorithm	algorithm of authorization for protocol v3 with security level "priv" and "auth".
Auth password	password of authorization for protocol v3 with security level "priv" and "auth".
Private algorithm	algorithm of authorization for protocol v3 with security level "priv".
Private password	password of authorization for protocol v3 with security level "priv".

SNMP Trap
×

Name	<input type="text"/>
Group	<input type="text" value="— no group —"/>
ID	
Type	
Class	
SNMP server	<input type="text"/>
SNMP port	<input type="text"/>
SNMP version	<input type="text" value="1"/>
Community	<input type="text"/>
USM user	<input type="text"/>
Security level	<input type="text" value="noauth"/>
Auth algorithm	<input type="text" value="MD5"/>
Auth password	<input type="text"/>
Private algorithm	<input type="text" value="DES"/>
Private password	<input type="text"/>

Save
Apply
Test
Cancel

Notification via SMS

To create notification via SMS you have to specify the following parameters:

Parameter	Description
Name	The name of the element in the system
Group	You can specify to which group the notification will be added in "Group tree" menu
Phone number	Phone number of receiver (+421908315000)
Message	Text of the message

Attention! In order for SMS to display correct time, make sure you have set the correct time zone in "Preferences" >> "Network" before sending SMS. The time zone has to be the same as the time zone of your browser (Operating system). See section "Creating notifications".

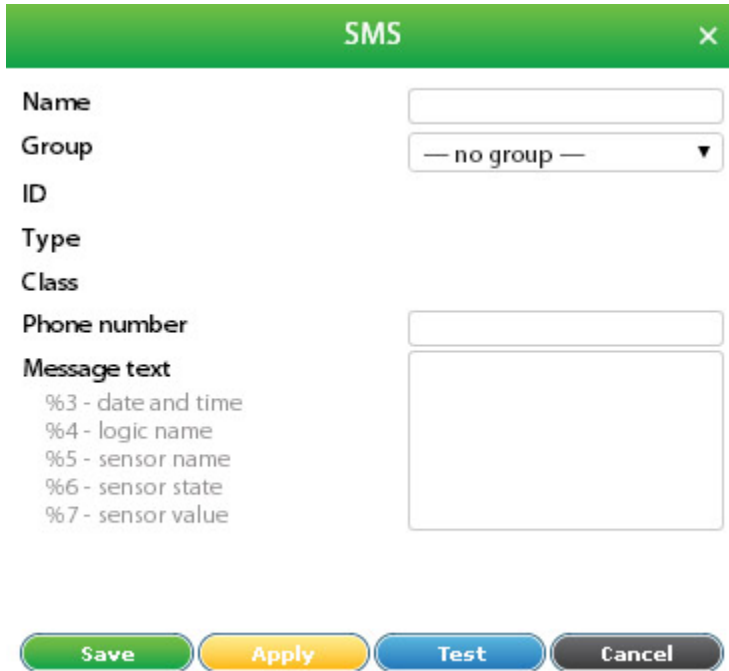

SMS [X]

Name

Group

ID

Type

Class

Phone number

Message text

- %3 - date and time
- %4 - logic name
- %5 - sensor name
- %6 - sensor state
- %7 - sensor value

[Save] [Apply] [Test] [Cancel]

Macros in the notification text

The text of the message can include macros. Macros have the following form:

%{number of macro}

When notification is created the system replaces the macros variables with actual values.

The following macros are available:

Macros	Description
%1	description of the logic scheme that has triggered
%2	readings of sensors in the logic scheme
%3	logic scheme response time
%4	name of logic scheme
%5	name of the sensor which triggered the logic scheme
%6	state of the sensor in the logic scheme that has triggered
%7	the value measured by the sensor or logic level
%8	sensor ID that triggered the operation of the logic circuit

Example. If the text has the following form:

```
%4
--
%1
--
%2
--
%3
```

When logic is triggered and the notification is sent, the recipient will see a message in the following form:

```
Logic scheme name
--
if 'S/N iButton'(id=13) in state 'alarm',
then
'Email'(id=302) changes to state 'on' immediately
'Relay-0'(id=31) changes to state 'pulse' immediately
--
'S/N iButton'(id=13) in state 'alarm'
--
12:40:36 2012/01/18
```

We recommend to use a more informative form of message, by default it is written in the following form:

```
Logic %4:
--
Defintion:
%1
Current sensor state:
%2
--
System time: %3
```

Macroses %5, %6, %7 are able to parameterize by element identifier {id}, i.e. for these macros may set the element for which will be evaluated macros.

Macroses evaluated example:

```
%5{1018} — print the name of element with id=1018 - 'sc470-0192-internal T°C';

%6{1018} — print the state of element with id=1018 - 'normal';

%7{1018} — print the value of element with id=1018 - '27.4'.
```

If an element with the specified identifier is not found in the text of the message is inserted - 'id = xxxx not found'.

If the parameter {id} is not specified, in the text of the message is inserted calculated value for the element that is triggered logical scheme .

- [Creating notifications \(v2.0.1 - v2.2.5\)](#)

Creating ping

Ping is a utility used to test the reach-ability of a host an a network. In the absence of connection ping registers from a normal state to a state of alarm. After you restore the connection - ping registers back to a normal state.

To create a "ping" utility, press add button " + " inside "Group tree" or "System tree" menu. Then choose "Ping". A modal window will appear.

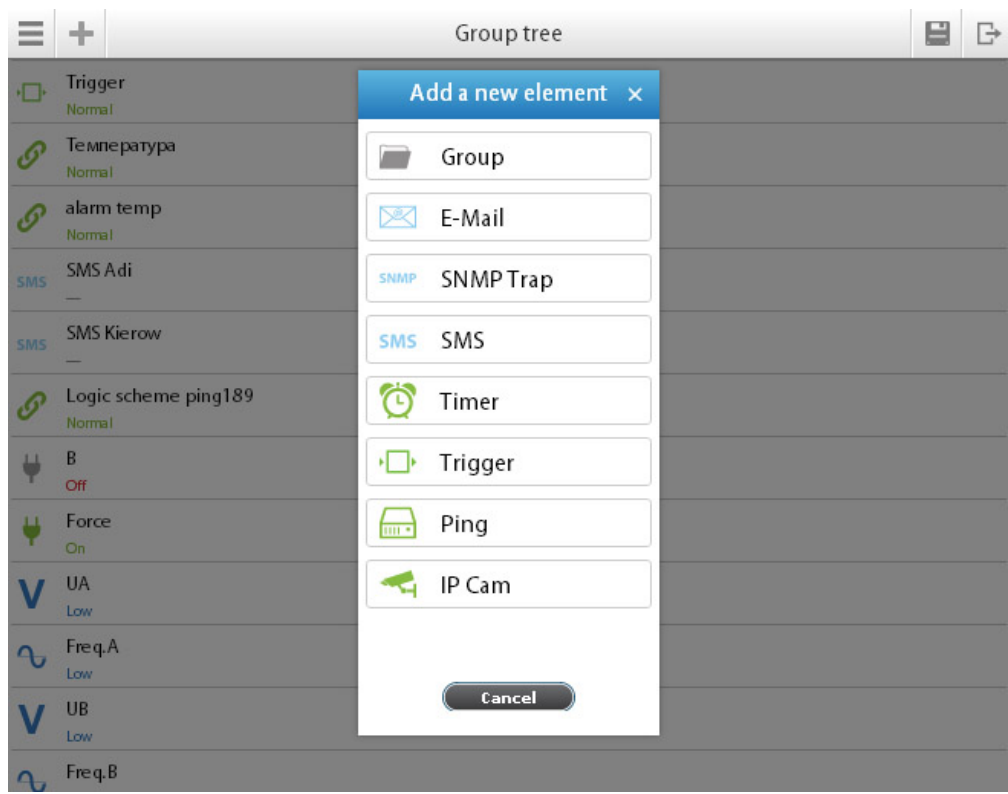

Ping



Name	<input type="text" value="Server #4"/>
Group	<input type="text" value="— no group —"/> ▼
ID	
Type	
Class	
Current state	
Current value	
Server to ping	<input type="text" value="145.123.0.13"/>
Ping period (sec.)	<input type="text" value="3"/>
Estimated round-trip (sec.)	<input type="text" value="5"/>
IP address	
Packets sent	

Packets received



Specify the server address, ping period, the estimated round-trip time between sending a request and receiving a response and press "Save".

- [Creating ping \(v2.0.1 - v2.2.5\)](#)

Creating timer

Timer allows you to plan the events in the system. When timer is triggered it goes from the normal state into alarm state. When timer is turned off it goes back to a normal state.

To create a "Timer" utility, press add button " + " inside "Group tree" or "System tree" menu. Then choose "Timer". A modal window will appear.

Timer ×

Name	<input type="text" value="Timer #1"/>
Group	<input type="text" value="— no group —"/>
ID	
Type	
Class	
Current state	
Period of operation	<input type="text" value="weekly"/>
Start time	<input type="text" value="AM 09"/> : <input type="text" value="15"/>
End time	<input type="text" value="AM 05"/> : <input type="text" value="20"/>
Days when timer is available	



Select timer mode: "Once" - one-time event, "Weekly" - every week, begin time, end time, days when timer is available (if selected "Weekly") and click "Save".

- [Creating timer \(v2.0.1 - v2.2.5\)](#)

Creating Get SNMP element

Virtual sensor "snmpget" is used to read data from external equipment via SNMP PDU GET (v2c).

To create a "SNMPGet", press add button " " inside "Group tree" or "System tree" menu. Then choose "snmpget". A modal window will appear:

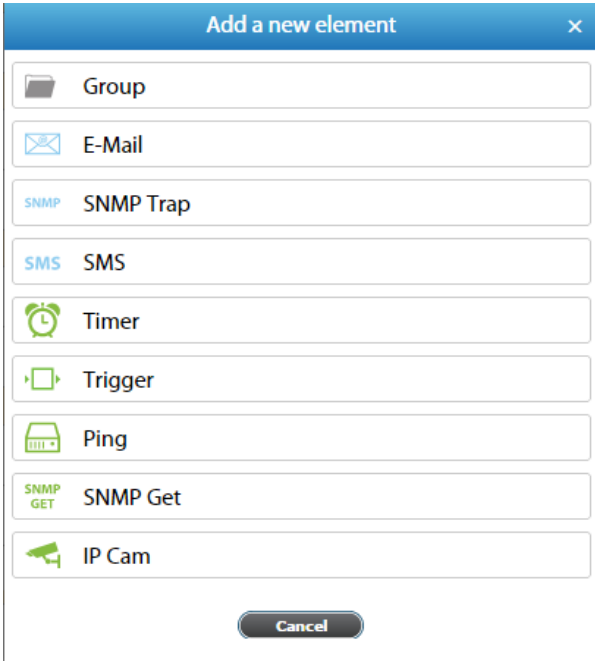

Click on the "SNMP Get". SNMP Get element form will be opened:

Name	<input type="text"/>
ID	<input type="text"/>
Type	snmpget
Class	notifier
Current state	Normal
Current value	0
Status	<input type="text"/>
SNMP server	<input type="text"/>
SNMP port	161
Community	<input type="text"/>
Polling period (sec.)	<input type="text"/>
OID Identifier	<input type="text"/>
Variable type	analog

Value for 'Low alarm'	<input type="text" value="0.0"/>
Value for 'Low warning'	<input type="text" value="0.0"/>
Value for 'High warning'	<input type="text" value="0.0"/>
Value for 'High alarm'	<input type="text" value="0.0"/>

Expression (f(x), for Instance: 2*x+123)

Fields in the form:

#	Name	Description
1	Name	Created element name
2	SNMP server	SNMP agent address
3	SNMP port	SNMP agent port
4	Community	Agent read community
5	Polling period	Period sending SNMP Get in seconds (at least 15 s)
6	OID identifier	The object identifier in the system
7	Variable type	Object type: <ul style="list-style-type: none"> analog - object gives the numerical value (string or integer), which is converted from a given expression to a real number. State of the element is determined by the calculated value and a predetermined levels; discrete - object gives an arbitrary value (string or integer). Expression in this case must contain the desired substring in the resulting value. If desired substring is found in the response, the state of the element is set to "normal", otherwise the item will be in a state of "alarm"
8	Expression	Depending from the type of object: <ul style="list-style-type: none"> analog - function of the form $f(x)$. The default value for the sensor is equal to the measured value: "x", ie corresponds to the expression "x". To calculate the indirect value of the sensor is possible to use an arbitrary expression, which are permissible "(", ")", as well as: <ul style="list-style-type: none"> operators: "+", "-", "*", "/" , "%" (remainder of the division), "^" (exponentiation); functions: "abs", "sqrt", "exp", "ln", "log", "sin", "cos", "tan", "asin", "acos", "atan"; constants: "pi" (3.1415926...), "e" (2.7182818...) For example: "0.1*x+0.5" discrete - any substring that is contained in the response in the normal state of the object;
9	The values for the levels	Level values to calculate the status of the element. It makes sense only for "analog" object

Add IP cam

Adding IP camera allows you to view footage from surveillance cameras remotely.

To create a "IP camera" utility, press add button "  " inside "Group tree" or "System tree" menu. Then choose "IP Cam". A modal window will appear.

IP Cam
×

Name	<input type="text" value="IP camera 0"/>
Group	<input type="text" value="— no group —"/>
ID	
Type	
Class	
URL (IP address)	<input type="text" value="http://telemetry.asia:8080/?acti"/>
Username	<input type="text"/>
Password	<input type="password"/>
Recommended FPS	<input type="text" value="1/15 sec"/>
Preview	

Specify IP address of IP camera; username and password if needed; then choose FPS and press "Refresh". IP camera should appear. If not, please check your settings. Then press "OK".

- [Adding IP camera \(v2.0.1 - v2.2.5\)](#)

Adding logic schemes

Logic schemes are used to specify automatic actions to events that occur in the system.

Logic schemes represent a set of conditions "IF" and a set of actions that are executed "THEN". Conditions can be combined

using "AND" and "OR". To carry out the actions it is possible to set required action repeat timeout. If timeout equals 0 the action will be executed once.

Logic scheme will work only if the combination of conditions is true. Otherwise the logic scheme will be disabled.

If logic scheme is disabled the reverse actions of actions in "THEN" will not be executed. To execute reverse actions you have to set up a new logic scheme.

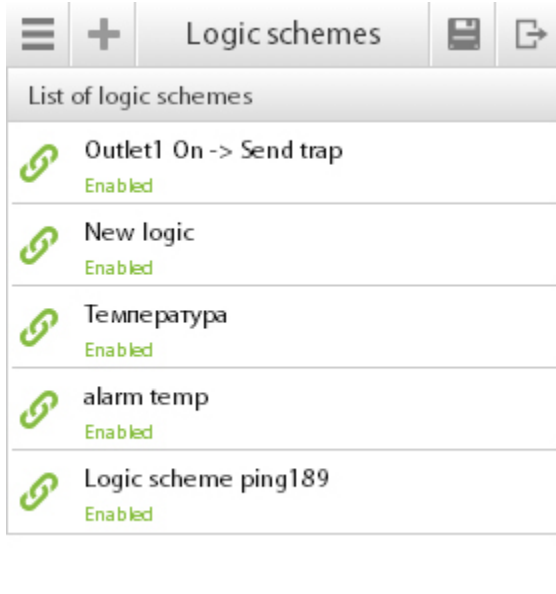

To add a new logic go to "Main menu" >> "Logic schemes" >> and press add button " + ". A modal window will pop-up.

To edit, deactivate or remove a logic scheme, click on any available logic schemes from the list.

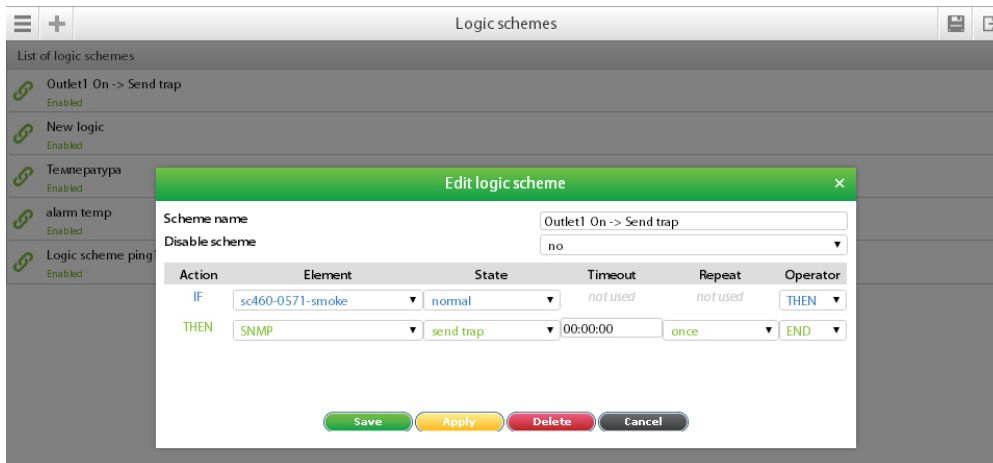

When editing or adding a logic scheme, specify the logic scheme name.

Create a set of conditions "IF". Select name of element in "Element" and state of element in "State" as a condition for logic. To add an additional condition use "AND" or "OR" in the field "Operator".

If a sensor with an analog output changes its state very rapidly (e.g. vibration sensor), the state of the element can change from "Low" to "Alarm" and vice versa, without going through the state of "Warning", and "Normal".

Create a set of executable actions "THEN". Select name of element in "Element" and state of element in "State" columns into which element goes after the logic is triggered.

If necessary, in "Timeout" field, specify the time in seconds to create a pause before the element switches into the new state after the logic is triggered.

If, within the specified time-out logic is deactivated, the element will not change its state.

Save created logic.

Example of adding a logic scheme

For example you have a telecommunication rack with servers and equipment. You need to activate fans inside a rack when temperature reaches 36°C. If temperature reaches 44°C you need to activate second fan and to notify the administrator via e-mail and SMS.

You have:

#	Device	Description
1	"Temperature"	Temperature sensor installed inside a rack
2	"Relay 1"	Controls fan #1
3	"Relay 2"	Controls fan #2
4	"E-mail"	Notification via e-mail. Created by user
5	"SMS"	Notification via SMS. Created by user

1. Edit the thresholds of "warning" and "alarm" levels for the temperature sensor. Set "warning level" to 36°C and "alarm level" to 44°C.

Temperature ×

Settings | Charts

Name: Temperature (sc460-0571)
Group: — no group —
ID: 1015
Type: temperature
Class: analog
Current state: **Alarm**
Current value: 25.5

Low level: 0.0
Warning level: 36.0
Alarm level: 44.0
K from (k*x + b): 1.000
B from (k*x + b): -3.0

Save Apply Cancel

2. Create "E-mail" and "SMS" notifications. Follow the steps in section [Adding logic schemes](#).

3. Go to "Logic schemes" menu. Add 3 logic schemes as follows:

a. First logic scheme will turn on Fan#1 when temperature reaches 36°C.

✕

Scheme name

Disable scheme

Action	Element	State	Timeout	Repeat	Operator
IF	Internal T°C	warning	not used	not used	THEN
THEN	Relay #1	on	00:00:00	once	END

b. Second logic scheme will turn on Fan#2 when temperature reaches 44°C. SMS and e-mail notifications will be sent.

✕

Scheme name

Disable scheme

Action	Element	State	Timeout	Repeat	Operator
IF	Internal T°C	warning	not used	not used	THEN
THEN	Relay #1	on	00:00:00	once	END

c. Third logic will turn off Fan#1 and Fan#2 when temperature falls into "normal" ("Normal" level is between "low" and "warning" levels. Thus below 36°C in this example).

✕

Scheme name

Disable scheme

Action	Element	State	Timeout	Repeat	Operator
IF	Internal T°C	normal	not used	not used	THEN
THEN	Relay #1	off	00:00:00	once	AND
THEN	Relay #2	off		once	END



Remember save the settings of elements and logic schemes in the flash memory of the device. Press "  " and then confirm.

- [Adding logic schemes \(v2.0.1 - v2.2.5\)](#)

Access control

Adding a key

Make sure you've connected i-Button reader. If not, follow instruction at "connecting 1-Wire reader".

To add a key to the access database, go to "  " >> press add button "  ".

Access control	
List of users and their electronic keys	
 Pete	AB9091276768D

A modal window will pop up:

Add a new key
×

Username

Key code

Save
Read
Download
Upload
Cancel

Press "Read". You will be prompted to touch the reader with the key in order to add a new user and then press "OK". Bring the key next to Proximity reader or touch the reader with the key. New key will be registered and dialog box will disappear. Default username (key name) can then be edited. Press "Save".

Uploading key database

If you want to upload a key database, go to "☰" >> press add button "+" >> press "Upload" >> "Choose File" >> choose your *.sqlite file.

Upload user database
×

Select file Choose File No file chosen

OK
Close

Adding a key manually

1. Enter username and the key code of the key. Most of the times you should find the code on the key. But it is normally written in a "every two digits reverse" way. For example:

Written on the key: 00-00-00-DC-39-C6

Written in the system: C6-39-DC-00-00-00

2. If you do not have the code written on the key, bring the key next to Proximity reader or touch the reader with the key. Go to "☰" >> "Event log" menu. Because the key has not been yet registered in the system, you find an error log message containing key code along with it. This is the code you need.

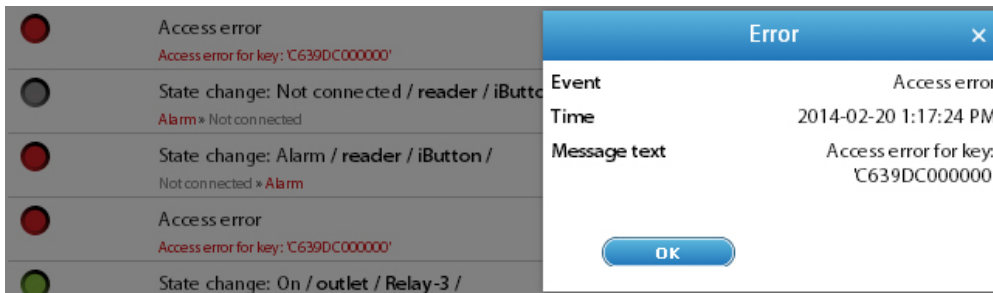

3. Press "Save".

Managing keys

To edit or delete keys in the key database, click on any user (key name) in "Access control" menu. You will get options to delete or edit the key.

If necessary, the existing key database can be saved into a file. This file can be used to create new database in another device or to restore the old database. Go to "Preferences" select "Access control", select "Download users database" or "Upload users database".

Export key database

If you want to export the whole key database, go to "☰" >> press add button "⊕" >> press "Download" >> you will be prompted to save the file in *.sqlite format.

- [Access control \(v2.0.1 - v2.2.5\)](#)

Setting up GSM modem

GSM modem is used to send SMS-notifications and to receive SMS-commands.

Configuring GSM modem

Before GSM modem can be used, you have to fill in the fields in the GSM modem properties window. Go to "System tree" menu and find GSM modem, click on it. A modal window with properties will open.

- Name – the name of GSM modem, "GSM Modem" by default;
- *Group* - groups are used in "Group tree" menu and are set manually by the user.
- Current state – the state of GSM modem;
 - not connected – GSM modem is not connected;
 - low – GSM modem is initiating or disconnecting;
 - normal – GSM modem is ready to send SMS;
 - warning – occurrence of a one-time error that does not affect the overall operation of the GSM modem;
 - alarm – occurrence of error that does not allow further operation of GSM modem.
- Current value - 0, ????
- IMEI – unique number that identifies the GSM modem;
- *Signal level* - the level of signal, values range from 0% to 100%.
- *Network registration* - ???
- Networkstatus – network status:
 - registered in Operator – registered in network Operator;
 - registered – registered in network;
 - not registered – not registered in home network;
 - registration denied – registration in home network is denied.
- Network status – network status:
 - not found – GSM modem is not found;
 - found, not ready – GSM modem is found but is not ready for operation;
 - found, ready – GSM modem is found and is ready for operation. In addition, this field shows errors that occur during operation of GSM modem e.g.error sending SMS.
- PIN code – PIN code of SIM card. This field can be empty if PIN code is deactivated on SIM card;
- Phone of SMS center - the number of SMS center. At connection the number is read from the SIM card. After editing the changes are saved on SIM card;
- List of allowed phone numbers - the list of numbers that are allowed to send SMS commands. SMS commands from any other number will not be executed. The number must begin with a "+".

GSM modem
×

Name	<input type="text" value="GSM Modem"/>
Group	<input type="text" value="— no group —"/>
ID	1004
Type	GSM modem
Class	devhwr
Current state	Alarm
Current value	0
IMEI	861785001228711
Signal level	0%
Network registration	no
Network status	not registered
GSM status	number of resets is exceeded
PIN code	<input type="text"/>
Phone of SMS centre	<input type="text"/>
List of allowed phone numbers	<input type="text" value="110"/>

Save
Apply
Cancel

To save the settings press "Save". In order to avoid repeating the procedure every time you connect monitoring system, the settings should be saved in the flash memory of the system. Press "  " and then confirm.

SMS notifications

For **more information on creating SMS** see section [Setting up GSM modem](#) .

To add recipient of SMS notification go to "System tree" or "Group tree" menu and press " ", then choose "SMS".

- Name – name of notification. Can be random (name, recipients position etc.) , "SMS" by default;
- Phone number – the recipients phone number. The number must begin with a "+".
- Message – the text of the message, can be in any language. The length of the message which contains latin characters is max 160, cyrillic characters - 70. If the length of the message exceeds this limit the SMS is split into several parts. In addition, this field allows you to edit macros (1%-7%) which insert the real values of the variables instead of the text.

To send a test message press "Test". The macros in the message text will be displayed in its original form (% ..). To save the notification properties, click "Save".

After filling in the properties of notification , you must specify the event, at occurrence of which SMS notification will be sent. To do this, go to "Logic schemes" menu >> press add button "  " and specify the conditions for sending SMS notifications.

For each new recipient you have to repeat the procedure of adding SMS notification.

Before messages are sent they are queued up, which means you do not have to wait until the previous message is sent. The information on all SMS sent is displayed in the log of monitoring system.

If an error occurs while sending a message, the log displays "SMS send error" and indicates the error number. The most common error is 515 (p.s . busy), which can occur when:

- not enough credit on the SIM card;
- wrong SMS centre number;
- low signal level (less than 15%) in the home network;
- wrong SMS format (the number must begin with a "+") or the number is invalid.

If these points do not cover your case, try to reboot the system. In addition, try to send SMS from your mobile phone, make sure the SMS centre number is the same.

SMS commands

SMS-commands are used for remote control of monitoring system. Using these commands, you can read the state and the measured values of sensors, control relays or outlets. Phone numbers from which the SMS commands will be sent, should be added to the list of allowed numbers in the modem properties (Click on GSM modem icon and edit "Allowed numbers"). In response to each SMS-command, a response SMS will be sent. In case of an error, an SMS will be sent with information about the error and an example of command. An SMS can contain only one command for only one element.

Command: reading sensor (relay, outlet) parameters

Function. get [id] or get [name], where id – number of the element, name – name of the element. Field "get" is not case sensitive, both can be used Get, GET. Field "name" is case sensitive.

Description. This command checks the state of the sensor or relay (outlet) and sends response SMS to the phone, from which the command was sent.

Examples.

- "get 1034" - to obtain information about the sensor with number 1034;
- "Get Analog-1" - to obtain information about the state of the element with the name of Analog-1;
- "GET Relay-2" - to obtain information about the state of the element with the name of Relay-2.
See section "Macros in the notification text" in [Setting up GSM modem](#) for further information.

Command: setting state of relay/outlet

Function. set [id] [state] or set [name] [state], where id – number of the element, name – name of the element, state – state to which relay/outlet switches. Field "set" and "state" are not case-sensitive. Field "name" is case-sensitive. Field "state" can be in the following states: on – switch on, off – switch off.

Description. This command switches the relay (outlet) in accordance with state parameter. In response it sends an sms notification to the phone number, from which the command was received, with result of the command.

Examples.

- "set 1004 on" - switch on relay with number 1004;
- "Set Relay-1 on" - switch on relay with name Relay-1;
- "SET Relay-2 Off" - switch off relay with name Relay-1;
- "set 1005 OFF" - switch off relay with number 1005.

Command: setting impulse of relay/outlet

Function. set [id] [name] pulse [duration], where id – number of the element, name – name of the element, duration – duration of delay in seconds. Field "name" is case sensitive. The range of values for field "duration" is from 1 to 120.

Description. This command switches the relay (outlet) two times with a temporary delay specified as a "duration" parameter in seconds.

Examples.

- "set 1004 pulse 15" - pulse is sent to the relay with number 1004 with delay time of 15 sec;
- "SET Relay-1 PULSE 110" - pulse is sent to the delay with name Relay-1 with delay of 110 sec;
- "set Relay-2 pulse 10" - pulse is sent to the relay with name Relay-2 with delay of 10 sec.

For errors related to GSM modem, leave comments on this page. Please indicate the firmware version of your monitoring system ("System menu" "About this system" "Firmware version").

Sending SMS from PC

You can use an external program to send SMS directly from your PC, [cURL](#) for example.

To follow the example please use the following command in console:

```
gcc -O2 -o sendsms sendsms.c
```

Script example of sending SMS

```
SMS script
#!/bin/bash
# SMS script for version 2.4.x

usage()
{
cat << EOF
usage: $0 options

OPTIONS:
-?,-h Show this message
-H Hostname or IP address
-u User name
-p Password
-P Phone for sending
-m Message for sending
EOF
}

HOSTIP=
USERNAME=
PASSWORD=
TOPHONE=
MESSAGE='Test'

while getopts "hH:u:p:P:m:" OPTION
do
case $OPTION in
h)
usage
exit 1
;;
H)
HOSTIP=$OPTARG
;;
u)
USERNAME=$OPTARG
;;
p)
PASSWORD=$OPTARG
;;
P)
TOPHONE=$OPTARG
;;
m)
MESSAGE=$OPTARG
;;
?)
usage
exit
;;
esac
```

done

```
if [[ -z $HOSTIP ]] || [[ -z $USERNAME ]] || [[ -z $PASSWORD ]] || [[ -z $TOPHONE ]] || [[ -z $MESSAGE ]]
then
    usage
    exit 1
fi
```

1) hash

```
HASH=`echo -n ${PASSWORD} | openssl dgst -sha1 | awk '{print $NF}'`
```

2) autorisation

```
RESPONSE=`curl -s -d "querytype=auth&name=${USERNAME}&h=${HASH}" "${HOSTIP}/engine.htm"`
```

3) session key

```
KEY=`echo -n ${RESPONSE} | awk -F"\"" '{print $4}'`
```

4) send SMS

```
curl
-d "querytype=send_sms_message&k=${KEY}" --data-urlencode
```

```
"to_phone=${TOPPHONE}" --data-urlencode "message=${MESSAGE}"  
${HOSTIP}/engine.htm > /dev/null 2>&1
```

- [Setting up GSM modem \(v2.0.1 - v2.2.5\)](#)

developer notes: linkchange

Setting up GSM modem (v2.0.1 - v2.2.5)

GSM modem is used to send sms-notifications and to receive sms-commands.

Configuring GSM modem

Before GSM modem can be used, you have to fill in the fields in the GSM modem properties window. Go to "GSM Modem" "Edit" "Edit GSM modem":

- Name – the name of GSM modem, "GSM Modem" by default;
- PIN – PIN code of SIM card. This field can be empty if PIN code is deactivated on SIM card;
- SMS Center – the number of SMS centre. At connection the number is read from the SIM card. After editing the changes are saved on SIM card;
- Allowed numbers – the list of numbers that are allowed to send SMS commands. SMS commands from any other number will not be executed. The number must begin with a "+".

Fields describing the status of GSM modem:

- IMEI – unique number that identifies the GSM modem;
- State – the state of GSM modem;
 - not connected – GSM modem is not connected;
 - low – GSM modem is initiating or disconnecting;
 - normal – GSM modem is ready to send SMS;
 - warning – occurrence of a one-time error that does not affect the overall operation of the GSM modem;
 - alarm – occurrence of error that does not allow further operation of GSM modem.
- Network status – network status:
 - registered in Operator – registered in network Operator;
 - registered – registered in network;
 - not registered – not registered in home network;
 - registration denied – registration in home network is denied.
- GSM status – general status of GSM modem:
 - not found – GSM modem is not found;
 - found, not ready – GSM modem is found but is not ready for operation;
 - found, ready – GSM modem is found and is ready for operation. In addition, this field shows errors that occur during operation of GSM modem e.g.error sending SMS.
- Signal strength – the level of signal, values range from 0% to 100%.

To save the settings press "Save". In order to avoid repeating the procedure every time you connect monitoring system, the settings should be saved in the flash memory of the system. Go to "System menu" "Save settings to flash".

SMS notifications

For **more information on creating SMS see section [Setting up GSM modem \(v2.0.1 - v2.2.5\)](#)** .

To add recipient of SMS notification go to "Add""Add Mailer SMS":

- Name – name of notification. Can be random (name, recipients position etc.) , "SMS" by default;
- Phone number – the recipients phone number. The number must begin with a "+".
- Message – the text of the message, can be in any language. The length of the message which contains latin characters is max 160, cyrillic characters - 70. If the length of the message exceeds this limit the SMS is split into several parts. In addition, this field allows you to edit macros (1%-7%) which insert the real values of the variables instead of the

text.

To send a test message press "Send sms". The macros in the message text will be displayed in its original form (% ..). To save the notification on properties, click "Save".

After filling in the properties of notification, you must specify the event, at occurrence of which SMS notification will be sent. To do this, go to "Preferences" "Logic schemes" "Add" and specify the conditions for sending SMS notifications.

For each new recipient you have to repeat the procedure of adding SMS notification.

Before messages are sent they are queued up, which means you do not have to wait until the previous message is sent. The information on all SMS sent is displayed in the log of monitoring system.

If an error occurs while sending a message, the log displays "SMS send error" and indicates the error number. The most common error is 515 (P s busy), which can occur when:

- not enough credit on the SIM card;
- wrong SMS centre number;
- low signal level (less than 15%) in the home network;
- wrong SMS format (the number must begin with a "+") or the number is invalid.

If these points do not cover your case, try to reboot the system. In addition, try to send SMS from your mobile phone, make sure the SMS centre number is the same.

SMS commands

SMS-commands are used for remote control of monitoring system. Using these commands, you can read the state and the measured values of sensors, control relays or outlets. Phone numbers from which the SMS commands will be sent, should be added to the list of allowed numbers in the modem properties (Right click on modem icon "Edit GSM modem" "Allowed numbers"). In response to each SMS-command, a response SMS will be sent. In case of an error, an SMS will be sent with information about the error and an example of command. An SMS can contain only one command for only one element.

Command: reading sensor (relay, outlet) parameters

Function. get [id] or get [name], where id – number of the element, name – name of the element. Field "get" is not case sensitive, both can be used Get, GET. Field "name" is case sensitive.

Description. This command checks the state of the sensor or relay (outlet) and sends response SMS to the phone, from which the command was sent.

Examples.

- "get 1034" - to obtain information about the sensor with number 1034;
- "Get Analog-1" - to obtain information about the state of the element with the name of Analog-1;
- "GET Relay-2" - to obtain information about the state of the element with the name of Relay-2.

See section "Macros in the notification text" in [Setting up GSM modem \(v2.0.1 - v2.2.5\)](#) for further information.

Command: setting state of relay/outlet

Function. set [id] [state] or set [name] [state], where id – number of the element, name – name of the element, state – state to which relay/outlet switches. Field "set" and "state" are not case-sensitive. Field "name" is case-sensitive. Field "state" can be in the following states: on – switch on, off – switch off.

Description. This command switches the relay (outlet) in accordance with state parameter. In response it sends an sms notification to the phone number, from which the command was received, with result of the command.

Examples.

- "set 1004 on" - switch on relay with number 1004;
- "Set Relay-1 on" - switch on relay with name Relay-1;
- "SET Relay-2 Off" - switch off relay with name Relay-1;
- "set 1005 OFF" - switch off relay with number 1005.

Command: setting impulse of relay/outlet

Function. set [id] [name] pulse [duration], where id – number of the element, name – name of the element, duration – duration of delay in seconds. Field "name" is case sensitive. The range of values for field "duration" is from 1 to 120.

Description. This command switches the relay (outlet) two times with a temporary delay specified as a "duration" parameter in seconds.

Examples.

- "set 1004 pulse 15" - pulse is sent to the relay with number 1004 with delay time of 15 sec;
- "SET Relay-1 PULSE 110" - pulse is sent to the delay with name Relay-1 with delay of 110 sec;

- "set Relay-2 pulse 10" - pulse is sent to the relay with name Relay-2 with delay of 10 sec.

For errors related to GSM modem, leave comments on this page. Please indicate the firmware version of your monitoring system ("System menu" "About this system" "Firmware version").

Sending SMS from PC

You can use an external program to send SMS directly from your PC. An example of such program and example of code in C can be found here:

http://sky-control.com:8090/download/attachments/1966111/920_sms.zip?version=1&modificationDate=1340695719493

The zip file Adobe AIR contains application and an example of code in C. To follow the example please use the following command in console:

```
gcc -O2 -o sendsms sendsms.c
```

To send SMS you can use a free software such as cURL:

Script example of sending SMS

```
#!/bin/bash

HOST=<IP or hostname EMS with GSM-modem, for example: http://telemetry.asia>
PASS=<your password>
PLUS='%2B'
TOPHONE=''$PLUS<your phone, for example: 421908xxxxxx>'
MESSAGE=<your message>

curl -d 'epassword=$PASS&querytype=send_sms_message&to_phone=$TOPHONE&message=$MESSAGE' $HOST/engine.f
```

developer notes: linkchange

Setting up CAN

CAN bus is used for connection of CAN sensors and CAN modules. The device has two independent CAN nodes: CAN1 and AN2.

Before using CAN sensor module, CAN bus must be configured in order to operate with this CAN sensor module. To configure CAN bus go to "Main menu" >> "CAN" menu, which in turn has two identical tabs - one for each node.

The screenshot displays the 'CAN configuration' web interface for 'CAN 2'. The interface includes a header with a menu icon, the title 'CAN configuration', and the user 'username: guest'. Below the header, there are tabs for 'CAN 1' and 'CAN 2', with 'CAN 2' selected. The main content area shows the following configuration details:

- Network name:** can0
- State:** up
- Mode:** normal
- Last update time:** 2015-02-04 9:26:29 AM

Below these details is a table with two columns: 'Product code' and 'Description'.

Product code	Description
sc470 (1)	Motion, vibration, temperature
sc408 (4)	8 analog (with auto detecting) sensors

At the bottom of the interface, there are four buttons: 'Refresh' (blue), 'Save' (green), 'Configure' (yellow), and 'Restart' (red).

Each station tab contains current information on the status of the node and a list of CAN sensor modules connected to this node.

The following operations can be carried out on CAN bus node:

- Refresh - updates the current information on the status of the node;
- Configure - launches configuration process of the nodes for CAN sensor modules connected to it, the old configuration is lost
- Save - saves the list of CAN sensor modules in flash memory;
- Restart - restarts the CAN bus node.

To delete a CAN sensor module, click on a desired module. A modal window will pop up. Press "Delete" and confirm.

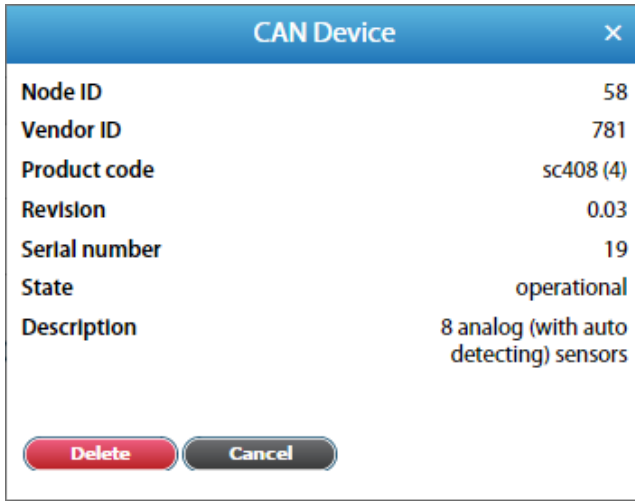

To set up a CAN bus node for operation with the CAN sensor module, connect CAN module to CAN network and run corresponding configuration procedure in the web-interface using command "Configure". The configuration process is displayed at the bottom of the tab and lasts approx. 2 minutes. Detected modules will be added to the list of modules during the configuration process. After completing configuration the node returns to its normal operation. Sensors of detected CAN modules are added to the tree of elements.

The names of the sensors are automatically set in the form {module name}{serial number}-{type of sensor} and can be edited.

If you need to remove CAN sensor module from the configuration list use command Delete, then use command "Save" to apply the changes you made and restart the node using command Restart.

- [Configuring VT408](#)
- [Setting up CAN \(v2.0.1 - v2.2.5\)](#)

Configuring VT408

The extension unit has built-in element:

- Power - relay type element
This element is identical to the element Analog Power of master module. It turns on or off the power of analog sensors. Turning off the power of analog sensors for a few seconds is used to reset the alarm smoke detectors VT560 connected to the extension unit VT408.
Warning: when the power of analog sensors is OFF, all connected to the VT408 external sensors are OFF.

The settings of analog sensors connected to VT408 unit are similar to the settings of sensors connected to the master unit.

Developer notes: addchange

Setting up dynamic DNS

Dynamic DNS is used to assign a persistent domain name to a device. The device allows to update Domain Name System to a point to a changing IP Address in automatic regime. Example of setting up Dynamic DNS service on [no-ip.com](#):

- Register on [no-ip.com](#) or login using an existing account.
- Create a host on [no-ip.com](#): "Add Host". Host parameters: Hostname - name of host , type: DNS Host (A), Ip Address: do not change, it will be automatically updated by device
- Go to web-interface of monitoring device "Preferences"->"Network". Select "Enable DynDNS". Select service: No-ip ([www.no-ip.com](#)), type in Login, Password and Hostname which you put in [no-ip.com](#). Save settings "Save".
- The device should update the IP address for the Hostname host after 1 minute. You can check this in the [no-ip.com](#) service. After some time the service will match IP address and Hostname.
- Using the Hostname in the browser open the web-interface of the device. If the host does not work try to use IP

address which will install the device on the no-ip.com service for the Hostname. If IP address does not work as well, this can happen if port 80 is closed and does not allow to host a server in your local network.

- [Setting up Dynamic DNS \(v2.0.1 - v2.2.5\)](#)

Logs export setting

To configure the export of logs go to "Main menu" >> "Preferences" >> "Syslog" >> "FTP server for log messages" in the Interface. Set the parameters of the export logs and press "Save".

Available options for exporting logs for the device are:

1	Syslog Server Address	indicate IP address of the Syslog server
2	FTP server for log messages	indicate address of the FTP server where to upload logs

- [Logs export setting \(v2.0.1 - v2.2.5\)](#)

Relay switching

Outlets switching for all units can be in "System tree" like in VT8101 unit.

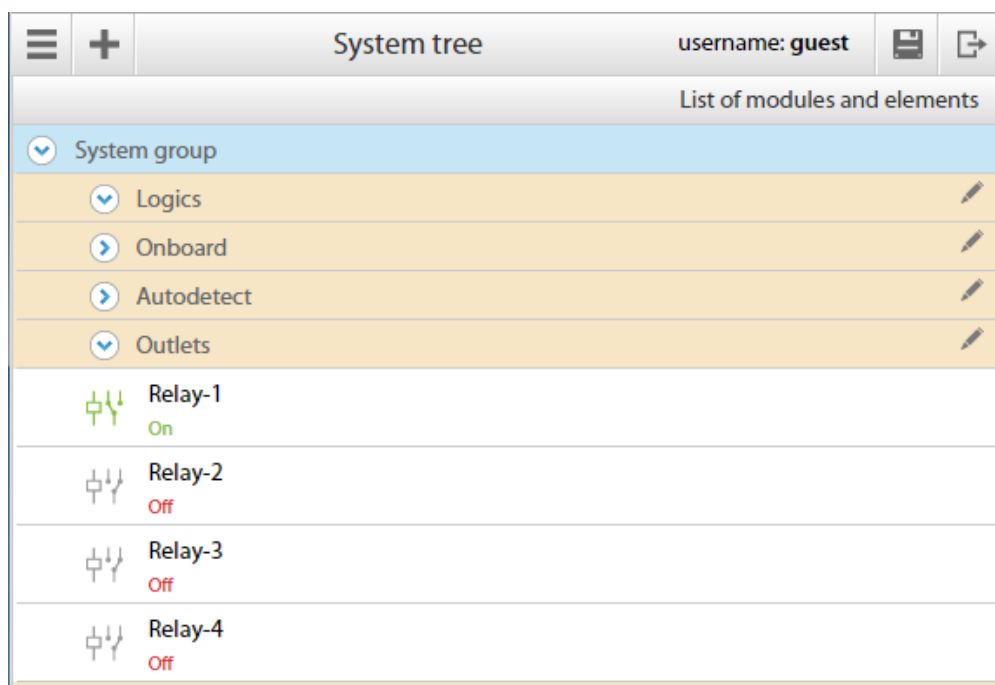

To switch on/off all relays for all units go in Main menu "  " >> "System Tree">>"Relay", click on the relay element and modal window with properties will pop up:

Relay
×

Settings

Charts

All data

Name

ID 301003

Type relay

Class switch

Hardware port 2

Current state Off

Current value 0

Initial state

Pulse duration (sec.)

OK

Apply

Pulse

Cancel

1	Name	Relay-# by default. Can be changed.
2	Group	Groupd can be selected for visual display in "Groupt tree" menu
3	Hardware port	Port 1 = relay 1/outlet 1; port 2 = relay 2/outlet 2 and so on.
4	Current state	Shows current state of relay
5	Current value	<ul style="list-style-type: none"> "0" - off "1" - on
6	Initial state	<ul style="list-style-type: none"> "off" - when the system starts, the relay will be switched off. "on" - when the system starts, the relay will be switched on.
7	New state	<ul style="list-style-type: none"> "do not change" - no impulse applied "pulse" - switches the relay into opposite state for a period of time specified in "pulse duration" field
8	Pulse duration	Measured in seconds. 1 second minimum.

Example: The relay is "Off". Let's say we need to switch it "On" for 30 seconds. In the field "New state" choose "pulse"; specify "Pulse duration" for 30 sec. Then press "Apply" or "Save". The relay will switch to "On" state for 30 seconds. Then it will return to "Off" state.

Outlets switching

To start managing relay switching of VT8110 / VT1908 go to "☰" >> "Outlets" menu. You should see relays:

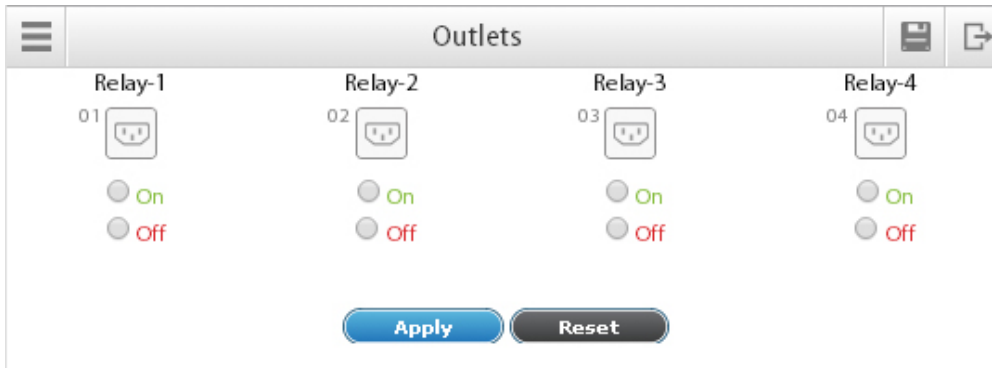

First choose which relays you need to switch to "On" or "Off" state, then press "Apply". Interface window will update itself in a moment:



For the picture above, we've switched "On" Relay-1 and Relay-3. They are highlighted by green color. Relay-2 and Relay-4 are currently off.

It is possible to manage each relay individually. For that go to "☰" >> "Group tree" or "System tree" menu >> click on any of the four relays.

"Pulse" parameter always changes relay's state to an opposite state.

- [Outlet management in PDU \(v2.0.1 - v2.2.5\)](#)

Outlet management in PDU (v2.0.1 - v2.2.5)

Outlets switching in SC1108 is different from the SC8100/8110.

The functionality

Following options are available for managing outlets:

- Setting the outlet in a Default state. Outlet has the status Default state when its condition was not changed by the user or by logic.
- Manual setting
- Automatic logic setting
- Formating of a given pulse duration by user's command or by the logic
- Setting limits on the simultaneous operation of the outlets. When the equipment is powered from a limited power source (e.g. UPS) it is necessary to limit the possible overloads. PDU has the possibility to set a pause between switching on power outlets, so that if the command is given for simultaneous switching on of outlets, they would switch on one by one after a certain time.

Settings

Each 8 outlets in the PDU System tree belong to a group of Block N

? Unknown Attachment

Each Block module has a panel "Module properties", which has the option to delay the relays - a slider Interval (ms). Interval determines the delay between relays switching on if several relays should be switched on at the same time. The minimum delay interval is 22 ms. Minimum delay interval for simultaneous operation of outlets is 22ms.

? Unknown Attachment

In addition, it is possible to set a default state for all relays. For this go to panel "Module properties" -> "Outlets Setup".

Individual outlets settings are set in panel "Sensor properties":

? Unknown Attachment

Default state - It is possible to set an initial default state for each outlet. The outlet will switch into this state when the system is started.

Pulse duration - it is possible to set pulse duration for each outlet. The pulse duration is set in seconds. Min duration is 1sec.

Attention: Do not forget to save the settings in Flash System Menu -> Save settings to flash

Outlets management

Tab "Outlets" - for switching outlets on/off through system interface

? Unknown Attachment

Button "Full off" is used for emergency shutdown of all outlets. When it is pressed all logics that were set are disabled. Attention! The system will issue a warning and ask for the current password!

The current state of outlets is displayed with different icon colour. Grey - switched OFF, green - switched ON.

The socket icon shows command being sent to change the state of relay. The line under the socket icon shows command being executed. The figure below shows

Outlet-2 and Outlet- 4: have already been switched to ON state.

Outlet-3: command is sent ; relay NOT switched ON because of time delay.

? Unknown Attachment

To change the state of the relay, tick the appropriate state and click Apply. Outlets that were not ticked will not change their current status.

Button Set OFF will set all the relays into OFF state, press button Apply to activate this function.

Logic

Outlets can be used in the creation of logics; both in executed actions (THEN) and in conditional inputs (IF).

Input conditions (IF) are checked against the actual state of the relay.

PDU's (including SC1108) have more relay states than modules SC8100/SC8110

A complete list of states:

- On
outlet has power
- Off
outlet has no power
- Alarm
command has been sent to outlet but has not been executed. This can occur when the system unit has lost its communication with the outlets module and at same time the system unit has been given a command to change relay state. In Alarm state all outlets from the same module will switch its state simultaneously. For this reason it is enough to check only one outlet to control the entire module.
- Not connected
The system unit has lost its communication with the outlets module. This state allows automatic and "transparent" (for the user) restoring of the normal operation

Saving system logs to SD card

Monitoring system uses SD-card to record changes in: logs, sensor data, configuration elements.

FAT32 and Ext4 (preferred) formats are supported.

SD-card must be first formatted by the user!

To manage the SD-card go to "Preferences" menu >> "SD Card" tab. If the SD card is not inserted, you should see empty fields:



Otherwise you should see:

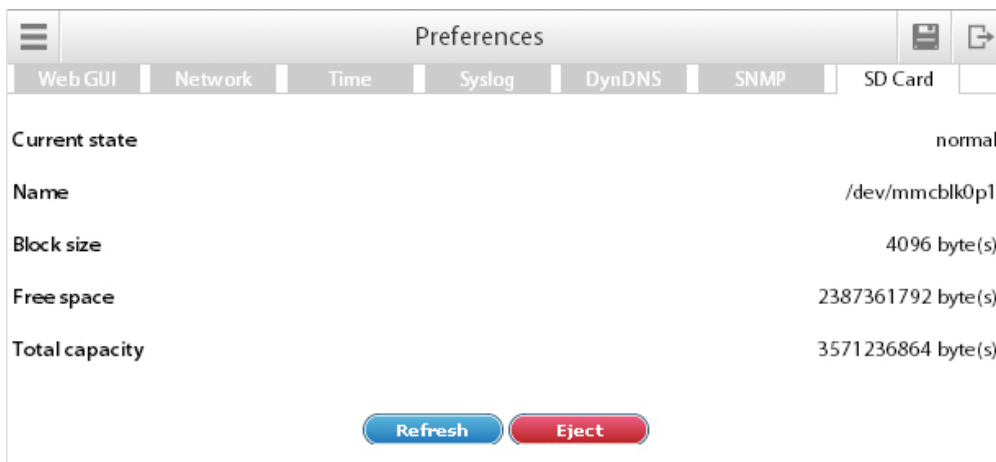

- "Refresh" - is used to update the page;
- "Umount" - is used to remove SD-card safely;

Information is recorded in 16KB blocks. The blocks are placed in a fixed-size file of 4MB. The current working file is named now .dump. If the size of the current working file exceeds 4Mb it is renamed in accordance with the serial number on the card into the file format dddddd.dump, where dddddd - is a decimal number. The older files have smaller sequence numbers, newer ones have higher. The oldest file is deleted when there is an insufficient space on the SD-card.

Utility used to parse dump on the memory card: [skydumpdecoder.jar](#)

To use this utility you need [JRE \(Java Runtime Environment\)](#) version 1.7

Decoding of the file can be performed as follows:

Sample:

```
java -jar skydumpdecoder.jar -i now.dump > mydump
```

Typical contents of the file mydump:

Sample:

```

0 LOG [1363159832] Wed Mar 13 11:30:32 MSK 2013 message: System hardware clock (UTC): 'Wed Mar 13 C
1 LOG [1363159834] Wed Mar 13 11:30:34 MSK 2013 message: Time synchronization for 'time.windows.com
...
12 LOG [1363159849] Wed Mar 13 11:30:49 MSK 2013 state: Sensor Analog-2 (id=1011) changed state fr
13 LOG [1363159849] Wed Mar 13 11:30:49 MSK 2013 state: Sensor Analog-3 (id=1012) changed state fr
14 DIFF [1363159849] Wed Mar 13 11:30:49 MSK 2013 [1012]=28.0;
15 DIFF [1363159886] Wed Mar 13 11:31:26 MSK 2013 [1001]=34.1;
16 DIFF [1363159892] Wed Mar 13 11:31:32 MSK 2013 [1001]=34.0; [1012]=27.9;
...
34 DIFF [1363160252] Wed Mar 13 11:37:32 MSK 2013 [1001]=33.7;
35 FULL [1363160253] Wed Mar 13 11:37:33 MSK 2013 [1001]={clas: "analog";type: "temperature";name: "Te

```

- Saving system logs to SD card (v2.0.1 - v2.2.5)

developer notes: linkchange

Dry contacts settings

Dry contacts window is designed to control dry contacts of VT440 and VT16. General view is shown here:

To create the logic for an arbitrary group of contacts press button  in the upper left corner. This starts a wizard to create a logic circuit.

As the first step of the wizard you must select the dry contacts to create logical scheme.

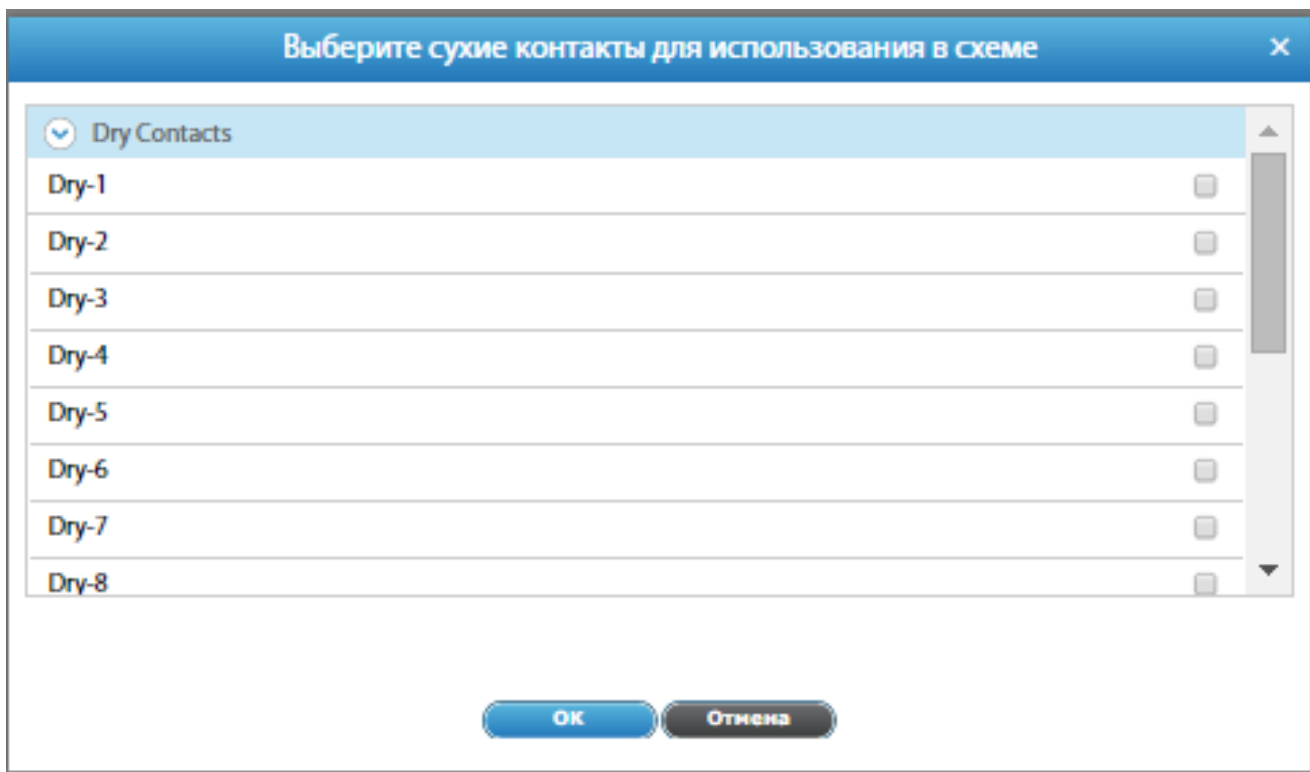

After you click OK, you are prompted to create a trigger.

Trigger
✕

Name

ID

Type trigger

Class devirt

Current state

Reversed

OK
Cancel

The trigger can be not created. But in this case, in THEN logic circuit can be used only existing elements. As the last step you need to edit and create a logic circuit with the OK button.

Add new logic scheme
✕

Scheme name

Disable scheme no

Action	Element	State	Timeout	Repeat	Operator
IF	Dry-1	alarm	not used	not used	AND
IF	Dry-2	alarm	not used	not used	AND
IF	Dry-3	alarm	not used	not used	AND
IF	Dry-4	alarm	not used	not used	AND
THEN	dry1to8	on	none	once	END

OK
Cancel

Do not forget to save all new settings and logic schemes into flash memory by clicking  in the right top corner of the interface!

Upgrade and restore options

The appliance has the possibility to update or to restore software.

You can update software via HTTP, FTP or using USB flash drive.

Restoring via USB can be done using a special recovery application.

The update process is displayed on the front panel with flashing LED "ERR". If successful, the "ERR" LED goes off, and "ACT" LED blinks for a while with increased frequency. If unsuccessful "ERR" LED remains lit.

Attention! Some of configurations may be lost (logic schemes, sensor data and parameters) when updating or restoring the system. Please read the notes of your update to know the specifics. Currently it is not possible to save changes, please make notes or screenshots of your configurations. Example: When updating from version 2.2.X to 2.4.X logic schemes and sensor parameters are lost.

Attention! **After updating the software clear browser history (cache). Otherwise, web interface may have problems associated with previous versions of files stored in cache on the device.**

To clear browser history in Mozilla Firefox follow: Tools->Clear Resent History

To clear browser history in Google Chrome follow: Settings->History->Clear All Browsing data

To clear browser history in other browsers see browser help section.

- HTTP upgrade
- FTP upgrade
- Upgrade via USB
- Restore of appliance
- Units type programming

HTTP upgrade

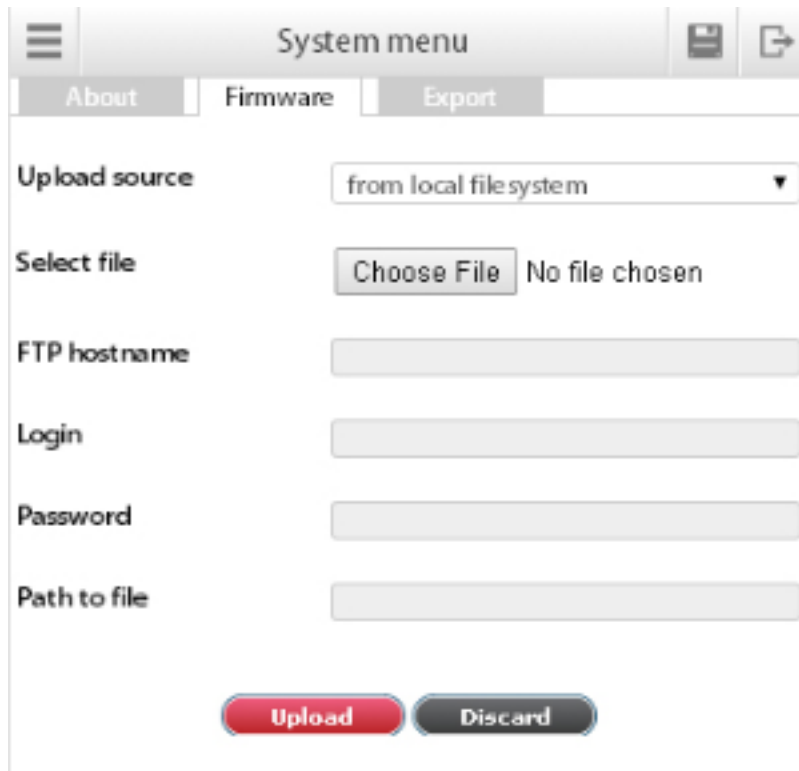

The screenshot shows the 'System menu' interface with the 'Firmware' tab selected. The 'Upload source' dropdown is set to 'from local filesystem'. Below it, the 'Select file' section shows a 'Choose File' button and the text 'No file chosen'. There are input fields for 'FTP hostname', 'Login', 'Password', and 'Path to file'. At the bottom, there are two buttons: 'Upload' (red) and 'Discard' (grey).

To update the software via interface (HTTP), first upload appropriate driver from our "drivers" section.

For drivers ver.2.4.5 and higher You should [download files](#) named: firmware-2.4xxxx.vut

For drivers ver.2.4.4 and lower You should [download files](#) named: sky25firmware.sky

Then go "System menu" >> "Firmware" tab >> "Upload source" >> "From local filesystem" >> "Choose file".

Select configuration file (sky25settings.sky) and press "OK". After the update is complete the web interface displays message "Firmware upload".

The updating process is indicated by LEDs on the front panel of the device: file installation is indicated by switching ERR, the end of the installation process is indicated by a short-term increase in switching frequency ACT. Then all the lights switches off - the system is rebooted. Completion is indicated by switching reboot ACT.

After the reboot (all LEDs are turned off) after 30-60 seconds, check the system operation.

- [via HTTP upgrade \(v2.0.1 - v2.2.5\)](#)

FTP upgrade

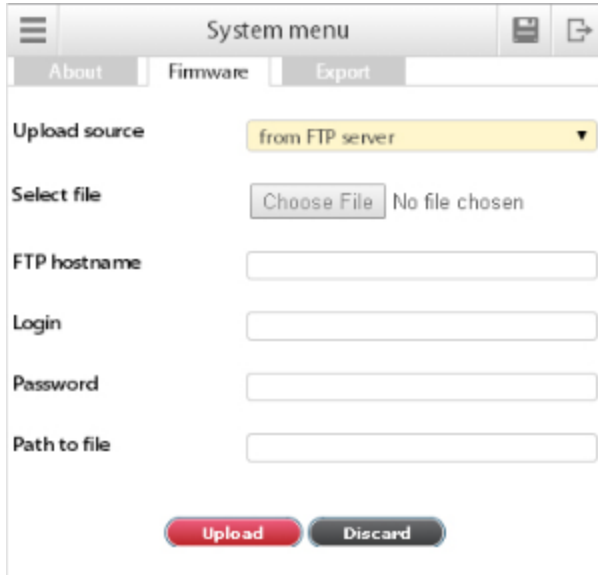

The screenshot shows a web interface titled "System menu" with three tabs: "About", "Firmware", and "Export". The "Firmware" tab is active. Under "Upload source", a dropdown menu is set to "from FTP server". Below this, there is a "Select file" section with a "Choose File" button and the text "No file chosen". There are four input fields: "FTP hostname", "Login", "Password", and "Path to file". At the bottom, there are two buttons: "Upload" (red) and "Discard" (grey).

To update the software via FTP, go to "System menu" >> "Firmware" tab >> "Upload source" >> "From FTP server".

Choose FTP hostname, login, password and if necessary, type in or change FTP path for the update file "firmware-2.4.xxxx.vut" in the field "Path to file". Save the settings using "Save". To update the software press "Upload".

For drivers ver.2.4.5 and higher You should [download files](#) named: firmware-2.4xxxx.vut

For drivers ver.2.4.4 and lower You should [download files](#) named: sky25firmware.sky

To update the software via interface (HTTP), first upload appropriate driver from our "drivers" section.

The updating process is indicated by LEDs on the front panel of the device: file installation is indicated by switching ERR, the end of the installation process is indicated by a short-term increase in switching frequency ACT. Then all the lights switches off - the system is rebooted. Completion is indicated by switching reboot ACT.

After the reboot (all LEDs are turned off) after 30-60 seconds, check the system operation.

The process of updating will be displayed on the LED on the front panel of the device.

- [FTP upgrade \(v2.0.1 - v2.2.5\)](#)

Upgrade via USB

To update the software via USB, first upload appropriate driver from our "drivers" section.

For versions 2.4.5 and higher You need to [download a files](#) named

firmware.vut - upgrade
settings.vut -settings reset
resetusers.vut - users password reset

Insert USB flash drive into the input "USB" and wait while the contents of drive will be analyzed by the device.

For versions 2.4.4 and lower You need to [download a file](#) named: sky25firmware.sky

Then copy the update file ("sky25firmware.sky"), the system settings file ("sky25settings.sky") or/and reset password file ("sky25resetusers.sky") into the root of USB-flash drive. Do not change the file names!

Insert USB flash drive into the input "USB" and wait while the contents of drive will be analyzed by the device.

The process of updating will be displayed on the LED on the front panel of the device.

The updating process is indicated by LEDs on the front panel of the device: file installation is indicated by switching ERR, the

end of the installation process is indicated by a short-term increase in switching frequency ACT. Then all the lights switches off - the system is rebooted. Completion is indicated by switching reboot ACT.

After the reboot (all LEDs are turned off) after 30-60 seconds, check the system operation.

Restore of appliance

Sometimes you may need a full software recovery in the appliance. You will need cable USB-A - miniUSB, PC with 32-bit operating system Windows, preferably Windows XP, with installed Microsoft Visual C + + 2008 Redistributable Package (x86) driver.

Attention! All user information and preferences will be destroyed forever if a full software recovery is used!

For versions 2.4.5 and higher download file updater.zip, for versions 2.4.4 and lower download file skyupdater.zip from the [drivers directory](#) (choose the version you need) or from supplied CD. Extract file into any folder on your PC, for example in C: \extract. Register USB driver. To do this go to subfolder C:\extract\windriver\ and run C:\extract\windriver\wd_install_4NT.bat file. If successfull, you will see in PC Task manager: Registered Windriver. Return to the unpacked folder C:\extract\ and run C:\extract\updater.exe or C:\extract\skyupdater.exe files.

Attention! Subfolder C:\extract\firmware\ must contain firmware.zip file!

1. Set the appliance to «Recovery mode». In order to do this, turn off the appliance and look at the back of metal case. You should see:

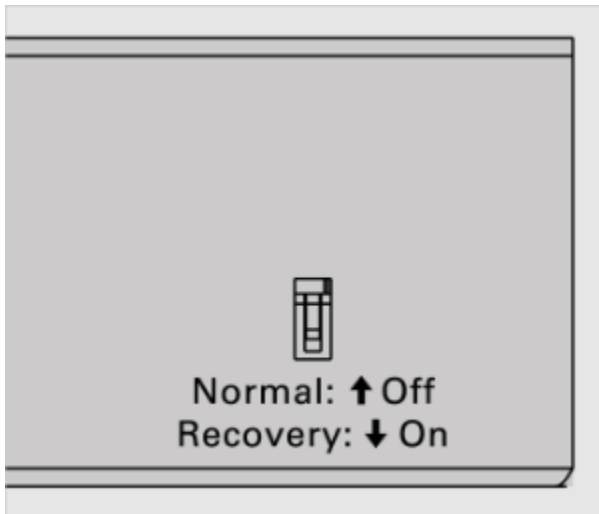

2. Switch the DIP to recovery mode.

3. If you do not have the DIP switch at the back, open the cover, switch the DIP switch 1 "Recovery" to the mode "ON" in the lower right corner of the motherboard. You may one of the two situations:

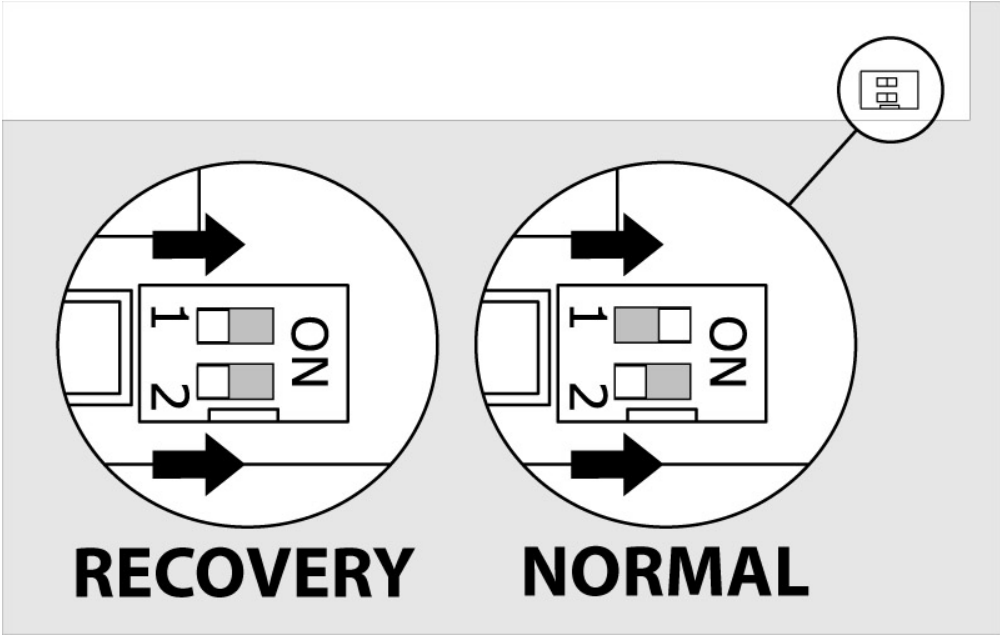

a)

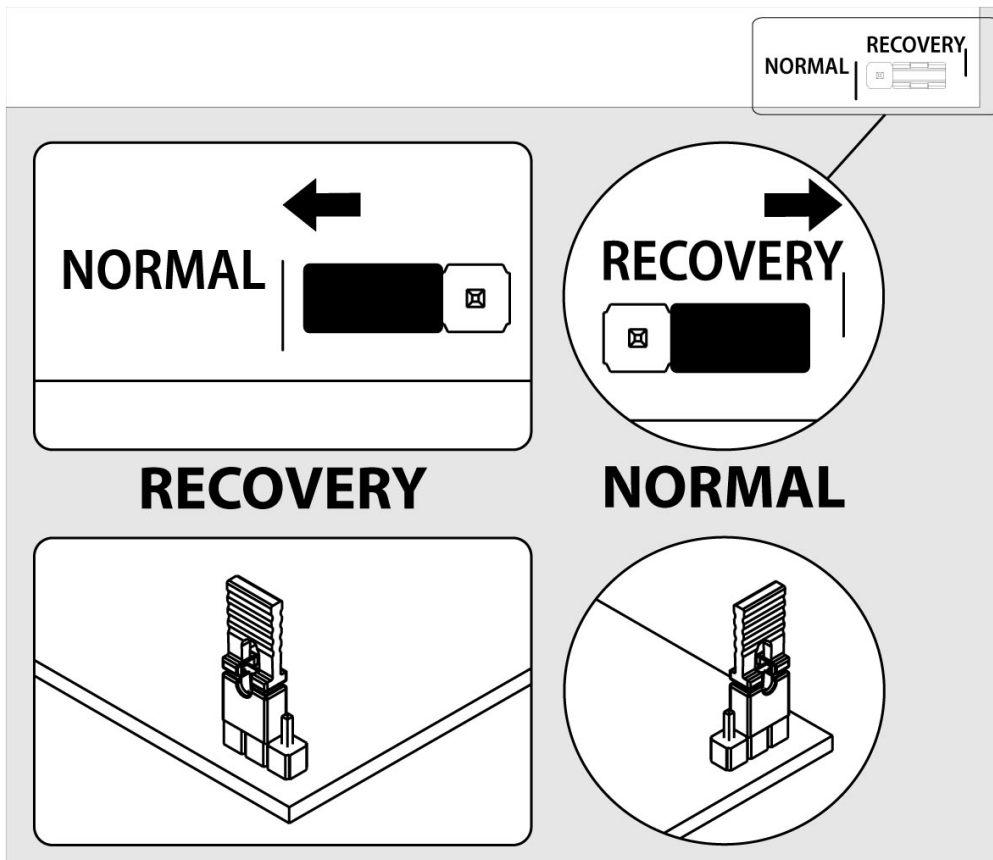

b)

If the appliance has a GSM modem, it must be turned off, disconnect modem cable from modem connector J5.

Close the cover of appliance, turn the power on, connect cable USB A - miniUSB port to PC USB input and "NS" input of appliance. The PC will detect the new USB device and will report that it can run faster. Start the New Hardware Wizard. Cancel the search for drivers on Windows update. It will then prompt you to install the driver for MX25. You should choose the automatic installation. After copying the files, a new device will be found and MX25 driver installation will be finished. PC Task Manager will record device (Jungo->MX25).

Test the USB connection, in order to do this, select "Test connection" in the field "Operation" and click item "Start". The program will connect to the appliance in a «Recovery» mode and display identification information.

Attention! Before starting operation, make sure you press the appliance "Reset" button or turn on/off the power, otherwise the program will not be able to connect appliance.

Set the appliance to «Normal» mode. In order to do this, turn off the appliance, open the cover, switch the DIP switch 1 "Recovery" in the lower right corner of the motherboard to the mode "OFF". Make sure that DIP switch 2 is set to "ON". If the appliance has GSM modem, connect modem cable back to modem connector J5. Close the cover, turn the power on, and test the system.

Disconnection and connection of connector labeled "J5 = Modem" should be performed only when the power is off.

- [Restore of appliance \(previous versions\)](#)

developer notes: linkchange

Units type programming

For setting the type of device in non-volatile memory, you must write to the command in the browser address bar:

[http://192.168.0.193/devtype.htm?name=\[Device type\]](http://192.168.0.193/devtype.htm?name=[Device type])

where the device IP address is specified and the type of device in accordance with the table below:

Vutlan	Skycontrol	Zertico	Device type	Autodetect sensor ports	Relay	Signal relay	Outlets	iButton
VT8101	SC8100	ZCOA-500	0	8	3	1	-	1
VT2100	SC2100	ZCOA-300	1	1	-	-	-	-
VT800	-	ZCOA-800	2	8	-	-	-	1
VT8110	SC8110	ZCOA-600	3	8	-	-	4	1
VT8101T	SC8100T	ZCOA-501	4	8	3	1	-	1
VT11xx	SC11xx	ZCOA-800	5	1	-	-	xx	-
VT18xx	-	-	6	1	-	-	xx	-
VT19xx	-	-	7	1	-	-	xx	-

For example:

[http://192.168.0.193/devtype.htm?name=\[Device type\]](http://192.168.0.193/devtype.htm?name=[Device type])

In case of successful entry will display a message like:

New name: VT8110 (3).

System will be restarted.

Then the system will automatically reboot and the changes will take effect.

In case of error:

Error writing new name!

If the record does not match the table, the algorithm is used to determine the type of device by boardstamp.

Cleaning, battery & fuse disposal and replacement

This section includes the following:

- [Disposal](#)
- [Battery replacement](#)
- [Fuse replacement](#)
- [Cleaning](#)

Disposal

Vutlan appliance contains replaceable silver oxide coin-cell battery SR44. Silver oxide batteries contain a small amount of mercury and can be recycled to recover it. Please take this into account when replacing the battery.

Battery replacement

SR44 batteries are required to store the date and current time on the device. Replacement batteries are required when storing the device without power supply for a long period of time, or when using the device after a long period of no use, or when using after the warranty period has expired.

Battery replacement is only possible when the power is turned off on the device!

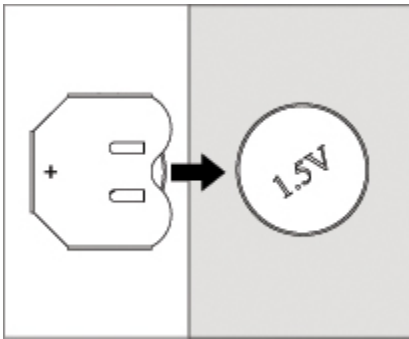

In order to do this, turn off the device from power, open the enclosure, carefully push aside the old battery and remove it. Check the place of battery installation for the absence of water stains or other damages, insert a new battery, close the unit cover, and connect the power supply. After connecting, synchronize the date and time.

If you cannot use the SR44 battery, it is possible to install LR44 batteries, however, bare in mind that these batteries can have a shorter period of storage and use, and that the alkaline batteries have tendency to leak.

Fuse replacement

Use the fuse 20x5mm.

Attention! When replacing a fuse, it is important to use the right fuse for the appliance, to make sure the fuse does not overheat! See section [Comparison chart: Master modules](#) for fuse specifications.

1. First, plug off the power cable 220V from the socket.
2. Then use a flathead screwdriver to remove the fuse from the main socket. Depending on the type of outlet, the fuse holder can be pulled out entirely or partly.

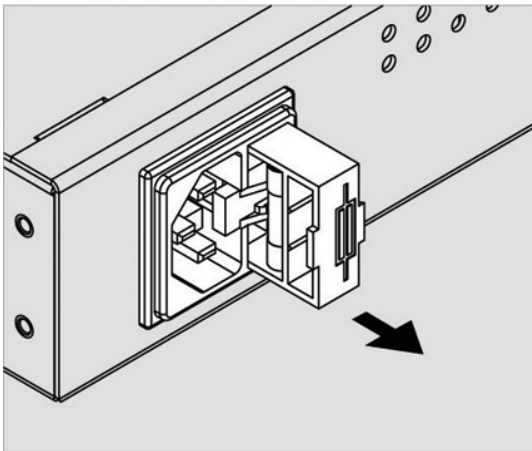
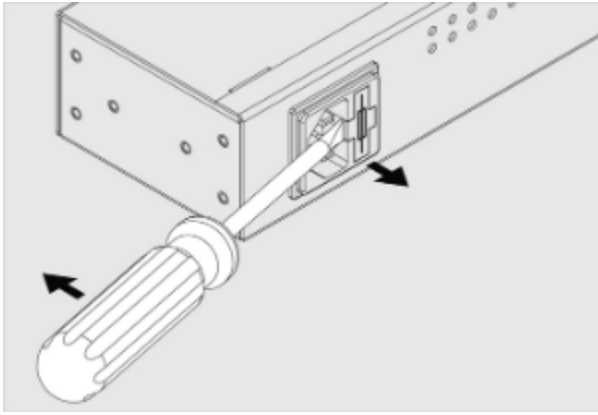

or

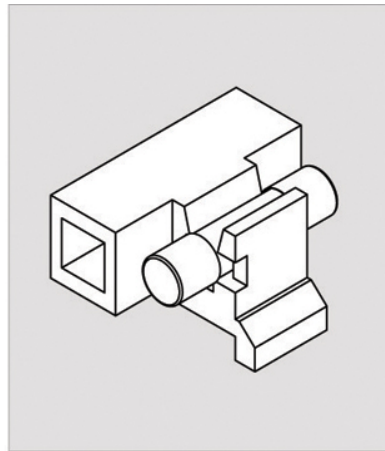

Attention! Make sure the plastic holder is not cold and its temperature is more than 20°C! The cold reduces the flexibility of plastic and can damage the parts.

3. If the fuse holder is cold, then put it in a warm place for some time, if you have such possibility.

4. When it warms up, remove the fuse by hands (or pushing it out with a screwdriver) and insert a new fuse. Then return the fuse holder in place.

Cleaning

Use a soft dry cloth to clean the appliance.

Warranty

This section includes the following:

- 2 year manufacturing warranty

2 year manufacturing warranty

Warranty is included in the appliance inventory. Please, carefully read the terms of the warranty. Save your warranty and the documents of sale in a safe place. These documents will be required for exercise of warranty service.

Warranty period

Appliance: two years from the date of original purchase.

Extensions and accessories: 90 days from the date of original purchase or the rated life of the unit, depending on which will end sooner.